



AUTO PUMP[®]

AP4 & AP4.5 CLASSIC SERIES

Operation Manual

AutoPump Controllerless System

For water remediation applications. For Professional use only.

MANUAL NUMBER X063558 | Revision A | ENGLISH (US)



Important Safety Instructions

Read all warnings and instructions in this manual before using the equipment.
Be familiar with the proper control and usage of the equipment. Save these instructions.

CONTENTS

Contents.....	2
Models	4
Safety Symbols	5
General Warnings.....	6
Technical Specifications	7
AP4 CLASSIC Low Draw Down Aggressive Fluids – Bottom Load.....	7
Flow Rates	8
Air Consumption.....	9
AP4 CLASSIC Short Ultra & High Temp. – Bottom Load.....	10
Flow Rates	11
Air Consumption.....	12
AP4 CLASSIC Short LTD Ultra – Bottom Load	13
Flow Rates	14
Air Consumption.....	15
AP4 CLASSIC Long Ultra & High Temp – Bottom Load	16
Flow Rates	17
Air Consumption.....	18
AP4 CLASSIC Low Draw Down Aggressive Fluids – Top Load.....	19
Flow Rates	20
Air Consumption.....	21
AP4 CLASSIC Short Ultra – Top Load	22
Flow Rates	23
Air Consumption.....	24
AP4 CLASSIC Long Ultra – Top Load.....	25
Flow Rates	26
Air Consumption.....	27
AP4.5 CLASSIC Ultra & High Temp. – Bottom Load.....	28
Component Identification	29
Parts 32	
Easy Fitting Install	39
Required tools	39
Cleaning	40
Required Tools	40
Disassembly.....	40
Cleaning The Pump.....	40

Reassembly.....	41
Troubleshooting.....	42
Patent Information	44
Terms, Conditions & Warranty.....	48
QED Information	48

MODELS



AP4 Models		
Aggressive Fluids		Warranty
Bottom Load		
302596C	PUMP, AP4 CLASSIC LOW DRAW DOWN AGGRESSIVE FLUIDS BOTTOM LOAD	Standard Warranty
302740C	PUMP, AP4 CLASSIC SHORT VISCOUS FLUIDS BOTTOM LOAD	Standard Warranty
Top Load		
303107C	PUMP, AP4 CLASSIC LOW DRAW DOWN AGGRESSIVE FLUIDS TOP LOAD	Standard Warranty
302734C	PUMP, AP4 CLASSIC SHORT VISCOUS FLUIDS TOP LOAD	Standard Warranty
Ultra		Warranty
Bottom Load		
303211C	PUMP, AP4 CLASSIC SHORT ULTRA BOTTOM LOAD	5 – Year Extended Warranty
303211CX	PUMP, AP4 CLASSIC SHORT ULTRA XTREME BOTTOM LOAD	5 – Year Extended Warranty
303223C	PUMP, AP4 CLASSIC LONG ULTRA BOTTOM LOAD	5 – Year Extended Warranty
303315C	PUMP, AP4 CLASSIC SHORT LTD BOTTOM LOAD	5 – Year Extended Warranty
Top Load		
303243C	PUMP, AP4 CLASSIC SHORT ULTRA TOP LOAD	5 – Year Extended Warranty
303244C	PUMP, AP4 CLASSIC LONG ULTRA TOP LOAD	5 – Year Extended Warranty
Ultra High Temperature		Warranty
Bottom Load		
303276C	PUMP, AP4 CLASSIC SHORT ULTRA HIGH TEMP BOTTOM LOAD	5 – Year Extended Warranty
303276CX	PUMP, AP4 CLASSIC SHORT ULTRA HIGH TEMP XTREME BOTTOM LOAD	5 – Year Extended Warranty
303277C	PUMP, AP4 CLASSIC LONG ULTRA HIGH TEMP BOTTOM LOAD	5 – Year Extended Warranty

AP4.5 Models		
Ultra		Warranty
Bottom Load		
303269CX	PUMP, AP4.5 CLASSIC ULTRA XTREME BOTTOM LOAD	5 – Year Extended Warranty
Ultra High Temperature		Warranty
Bottom Load		
303312CX	PUMP, AP4.5 CLASSIC ULTRA HIGH TEMP XTREME BOTTOM LOAD	5 – Year Extended Warranty

Warranty Note: Warranty coverage, terms, conditions limitations, and exclusions are governed exclusive by the Standard Warranty Terms and Conditions set forth on page [42] of this manual. The notation above identifies eligibility for an extended warranty duration only and does not modify, expand, or replace applicable warranty terms.

SAFETY SYMBOLS

The following safety symbols appear throughout this manual and on warning labels. Read the table below to understand what each symbol means.

SYMBOL	MEANING
	Equipment Misuse Hazard
	Follow Pressure Relief Procedure
	Wear Personal Protective Equipment





Safety Alert Symbol



This symbol indicates: Attention! Become Alert! Look for this symbol throughout the manual to indicate important safety messages.

GENERAL WARNINGS

The following warnings are for the setup, use, grounding, maintenance, and repair of this equipment. The exclamation point symbol alerts you to a general warning and the hazard symbols refer to procedure-specific risks. When these symbols appear in the body of this manual or on warning labels, refer back to these Warnings. Product-specific hazard symbols and warnings not covered in this section may appear throughout the body of this manual where applicable.

 WARNING	
 	<p>EQUIPMENT MISUSE HAZARD</p> <p>Misuse can cause death or serious injury.</p> <ul style="list-style-type: none">• Do not operate the unit when fatigued or under the influence of drugs or alcohol.• Do not exceed the maximum working pressure or temperature rating of the lowest rated system component. See Technical Data in all equipment manuals.• Depressurize all equipment before disassembly.• Use fluids and solvents that are compatible with equipment wetted parts. See Technical Data in all equipment manuals.• Do not leave the work area while equipment is energized or under pressure.• Turn off all equipment and disconnect airlines when equipment is not in use.• Do not alter or modify equipment. Alterations or modifications may void agency approvals and create safety hazards.• Make sure all equipment is rated and approved for the environment in which you are using it.• Use equipment only for its intended purpose. Call QED Environmental for information.• Route hoses and cables away from traffic areas, sharp edges, moving parts, and hot surfaces.• Do not kink or over bend hoses or use hoses to pull equipment.• Keep children and animals away from work area.• Comply with all applicable safety regulations.
	<p>PERSONAL PROTECTIVE EQUIPMENT</p> <p>Wear appropriate protective equipment when in the work area to help prevent serious injury, including eye injury, hearing loss, inhalation of toxic fumes, and burns. This protective equipment includes but is not limited to:</p> <ul style="list-style-type: none">• Protective eyewear, and hearing protection.• Respirators, protective clothing, and chemically resistant gloves

TECHNICAL SPECIFICATIONS

AP4 CLASSIC LOW DRAW DOWN AGGRESSIVE FLUIDS - BOTTOM LOAD

Model Numbers: 302596C

GENERAL SPECIFICATIONS

Liquid Inlet Location: Bottom
OD: 3.6 in. (9.1 cm)
Length Overall: 25.9 in. (65.8 cm)
Weight: 11.7 lbs. (5.3 kg)
Max. Flow Rate: 7 gpm (26.5 lpm) - See Flow Rate Chart
Pump Volume / Cycle: 0.11 - 0.16 gal (0.42 - 0.61 L)
Min. Actuation Level: 15.3 in. (39 cm)

DEPTH AND PRESSURE

Maximum Depth: 250 ft. (76 m)
Air Pressure Range: 5 - 120 psi (0.4 - 8.4 kg/cm²)
Air Usage: 0.32 - 2.86 scf / gal. (2.2 - 21.5 liters of air / fluid liter) - See Air Usage Chart

CONSTRUCTION MATERIALS

Pump Body: Fiberglass
Pump Ends: 316 Stainless Steel
Internal Components: 316 Stainless Steel, Viton, PVDF
Tube & Hose Fittings: 316 Stainless Steel
Fitting Type: Barbs or Quick Connects or Easy Fittings

TUBE & HOSE OPTIONS

Tubing Material: Nylon
Sizes - Liquid Discharge: 1 in. (25 mm) or 1-1/4 in. (32 mm) OD
Pump Air Supply: 1/2 in. (13 mm) OD
Air Exhaust: 5/8 in. (16 mm) OD
Hose Material: Nitrile
Sizes - Liquid Discharge: 3/4 in. (19 mm) or 1 in. (25 mm) ID
Pump Air Supply: 3/8 in. (9.5 mm) ID
Air Exhaust: 1/2 in. (13 mm) ID

APPLICATION LIMITS

The AP4 is designed to handle the application ranges described below.

Maximum Temperature: Up to 180°F (82°C)
pH Range: 2 - 12 pH
Salinity: Up to 270 ppm (150 ppm chloride) at 180°F (82°C)
Up to 405 ppm (225 ppm chloride) at 140°F (60°C)
Up to 9000 ppm (5000 ppm chloride) at 50°F (10°C)

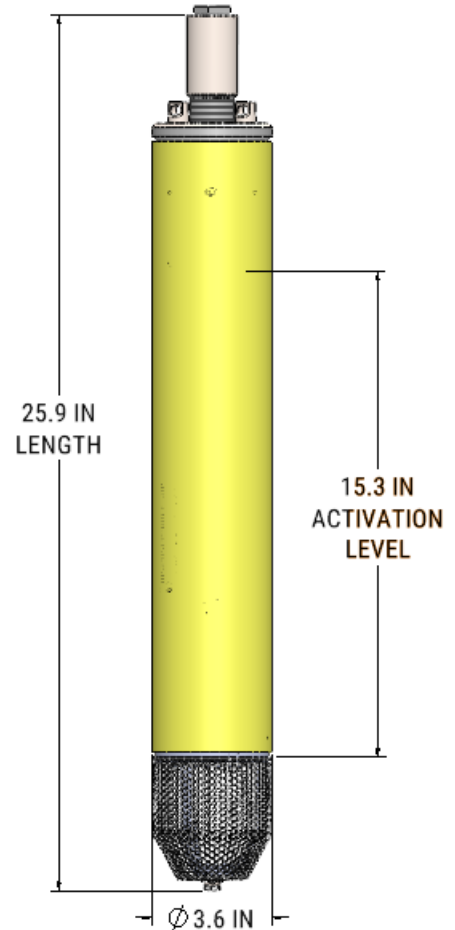

FLOW RATES

Flow rates may vary with site conditions.

3/4 inch (19mm)
Inside Diameter Discharge Hose
 (Equivalent to 1 inch OD Tubing)

1 inch (25mm)
Inside Diameter Discharge Hose
 (Equivalent to 1.25 inch OD Tubing)

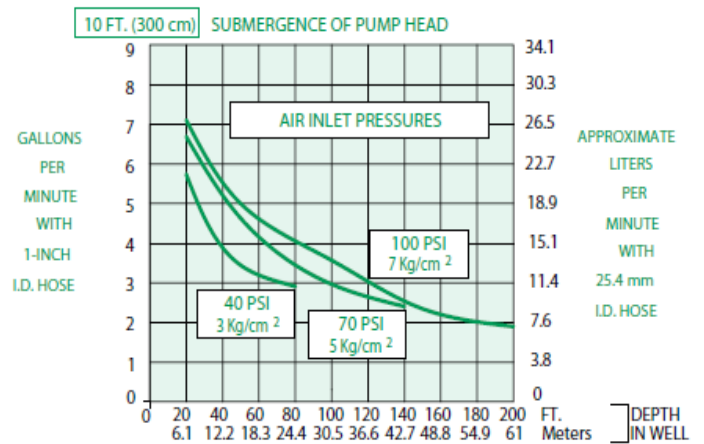
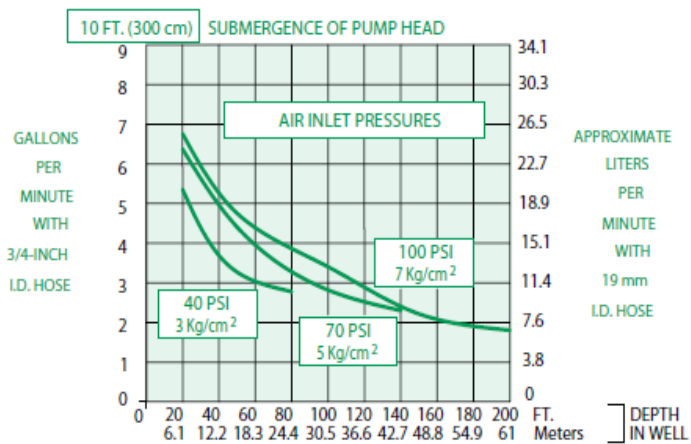
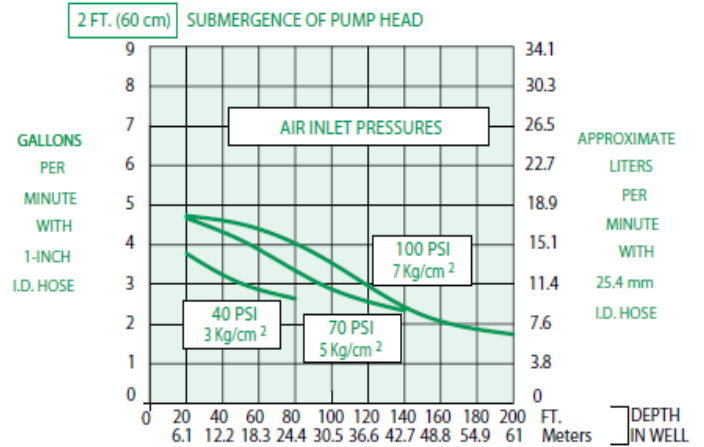
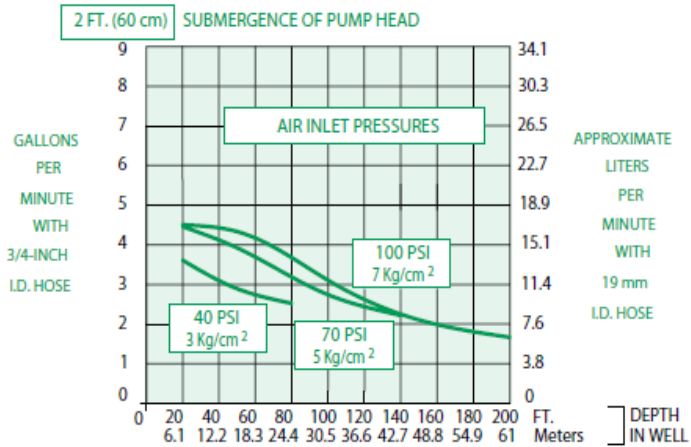
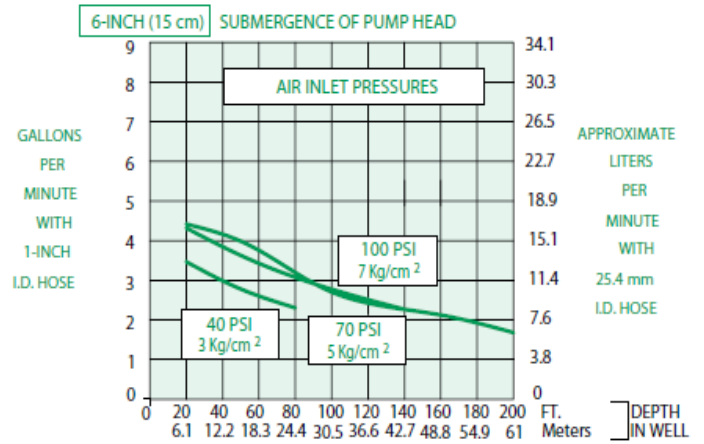
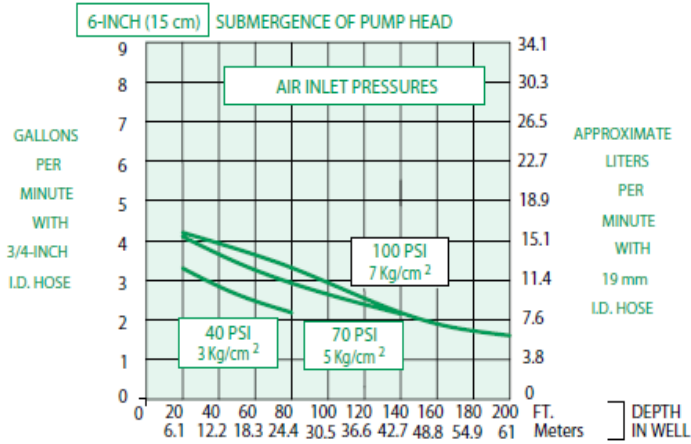

AIR CONSUMPTION

STANDARD CUBIC FEET OF AIR PER GALLON PUMPED (SCF/GAL)

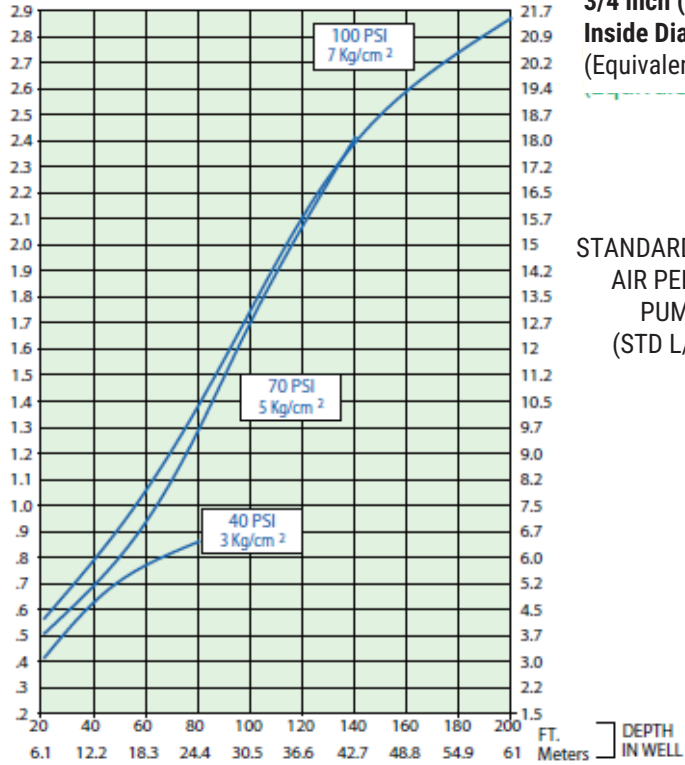

STANDARD LITER OF AIR PER LITER PUMPED (STD L/LITER)

STANDARD CUBIC FEET OF AIR PER GALLON PUMPED (SCF/GAL)

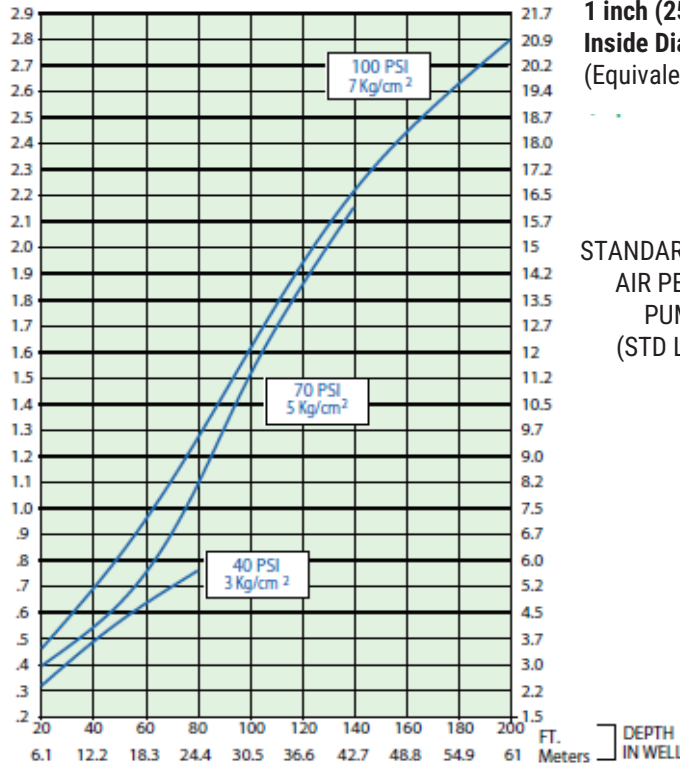

STANDARD LITER OF AIR PER LITER PUMPED (STD L/LITER)

AP4 CLASSIC SHORT ULTRA & HIGH TEMP. - BOTTOM LOAD

Model Numbers: 303211C, 303276C, 302740C, 303211CX, 303276CX

GENERAL SPECIFICATIONS

Liquid Inlet Location:	Bottom
OD:	3.6 in. (9.1 cm)
Length Overall:	39.6 in. (100.6cm)
Weight:	13 lbs. (7.3 kg)
Max. Flow Rate:	13 gpm (53 lpm) - See Flow Rate Chart
Pump Volume / Cycle:	0.22 – 0.36 gal (0.83 – 1.36 L)
Min. Actuation Level:	26.7 in. (67.8 cm)

DEPTH AND PRESSURE

Maximum Depth:	250 ft. (76 m)
Air Pressure Range:	5 – 120 psi (0.4 – 8.4 kg/cm ²)
Air Usage:	0.4 – 1.1 scf / gal. (3.0 – 8.5 liters of air / fluid liter) - See Air Usage Chart

CONSTRUCTION MATERIALS

Pump Body:	Fiberglass or Stainless Steel
Pump Ends:	316 Stainless Steel
Internal Components:	316 Stainless Steel, Viton, PVDF
Tube & Hose Fittings:	316 Stainless Steel
Fitting Type:	Barbs or Quick Connects or Easy Fittings

TUBE & HOSE OPTIONS

Tubing Material:	Nylon
Sizes - Liquid Discharge:	1 in. (25 mm) or 1 – 1/4 in. (32 mm) OD
Pump Air Supply:	1/2 in. (13 mm) OD
Air Exhaust:	5/8 in. (16 mm) OD
Hose Material:	Nitrile
Sizes - Liquid Discharge:	3/4 in. (19 mm) or 1 in. (25 mm) ID
Pump Air Supply:	3/8 in. (9.5 mm) ID
Air Exhaust:	1/2 in. (13 mm) ID

APPLICATION LIMITS

The AP4 is designed to handle the application ranges described below.

Maximum Temperature:	Up to 250°F (121°C) with certain models
pH Range:	4 – 12 pH
Salinity:	Up to 270 ppm (150 ppm chloride) at 180°F (82°C) Up to 405 ppm (225 ppm chloride) at 140°F (60°C) Up to 9000 ppm (5000 ppm chloride) at 50°F (10°C)

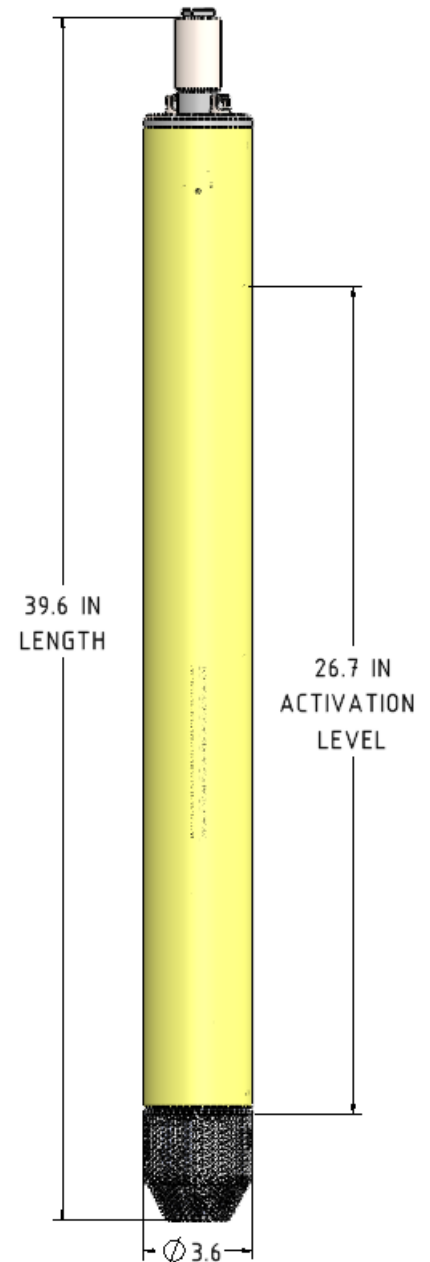

FLOW RATES

Flow rates may vary with site conditions.

3/4 inch (19mm)
Inside Diameter Discharge Hose
 (Equivalent to 1 inch OD Tubing)

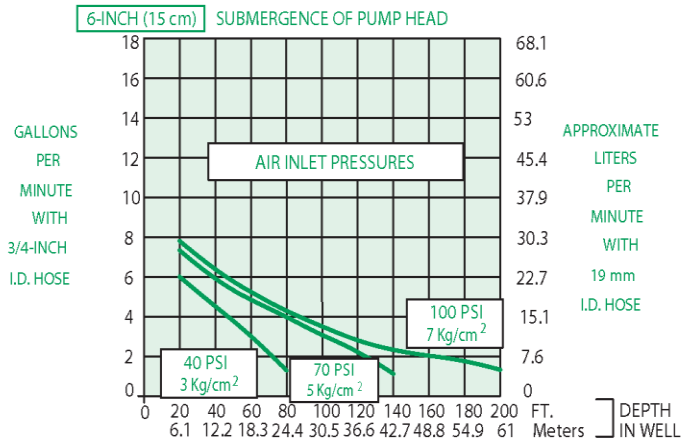

1 inch (25mm)
Inside Diameter Discharge Hose
 (Equivalent to 1.25 inch OD Tubing)

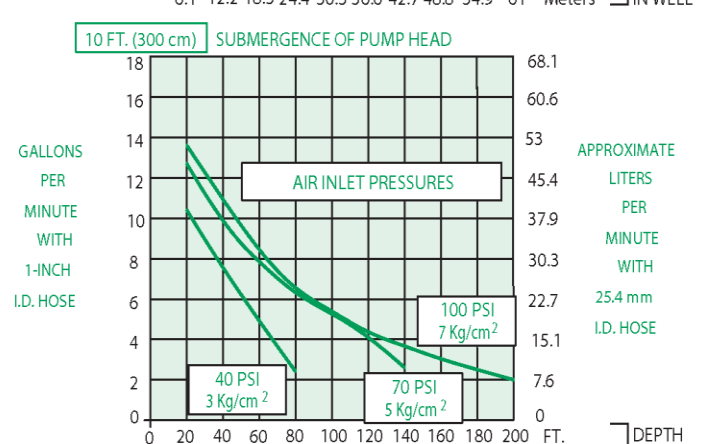
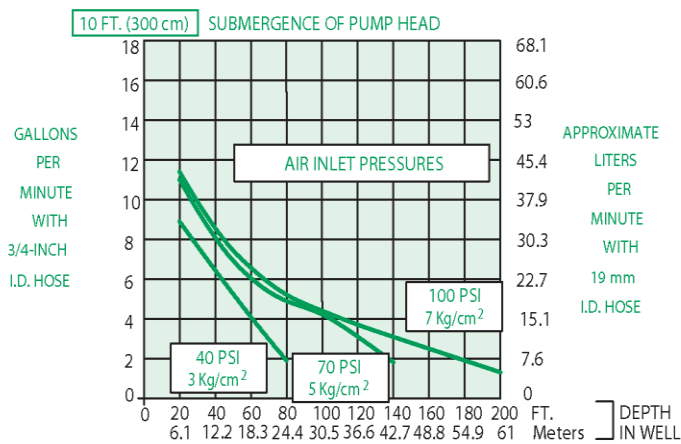
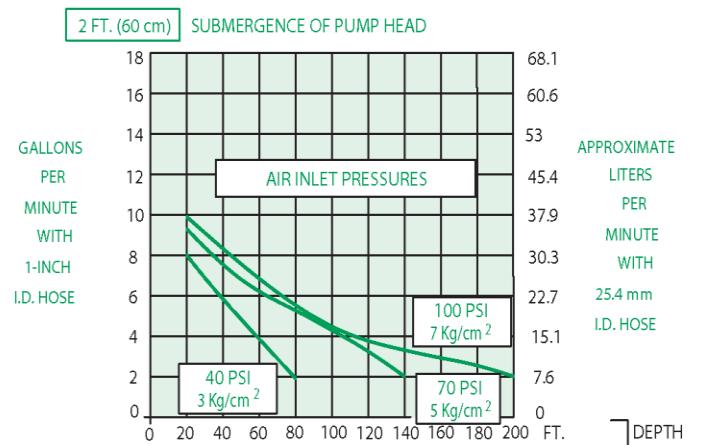
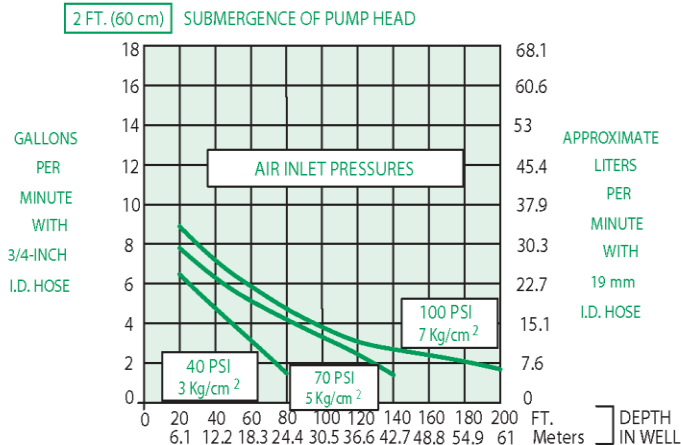
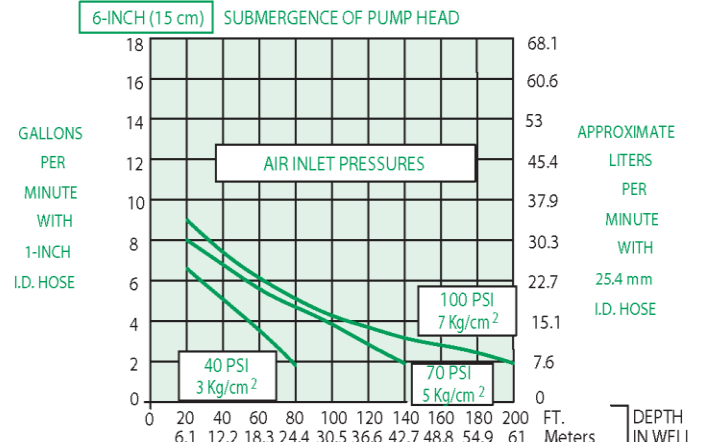

AIR CONSUMPTION

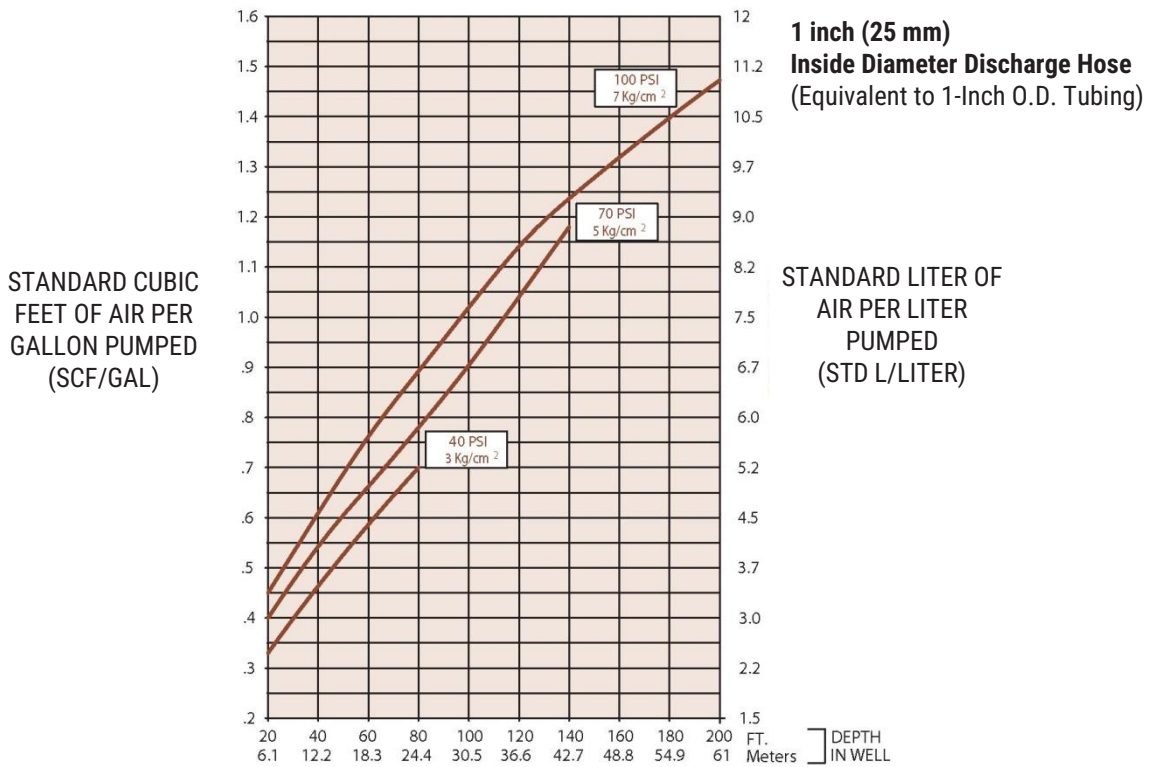
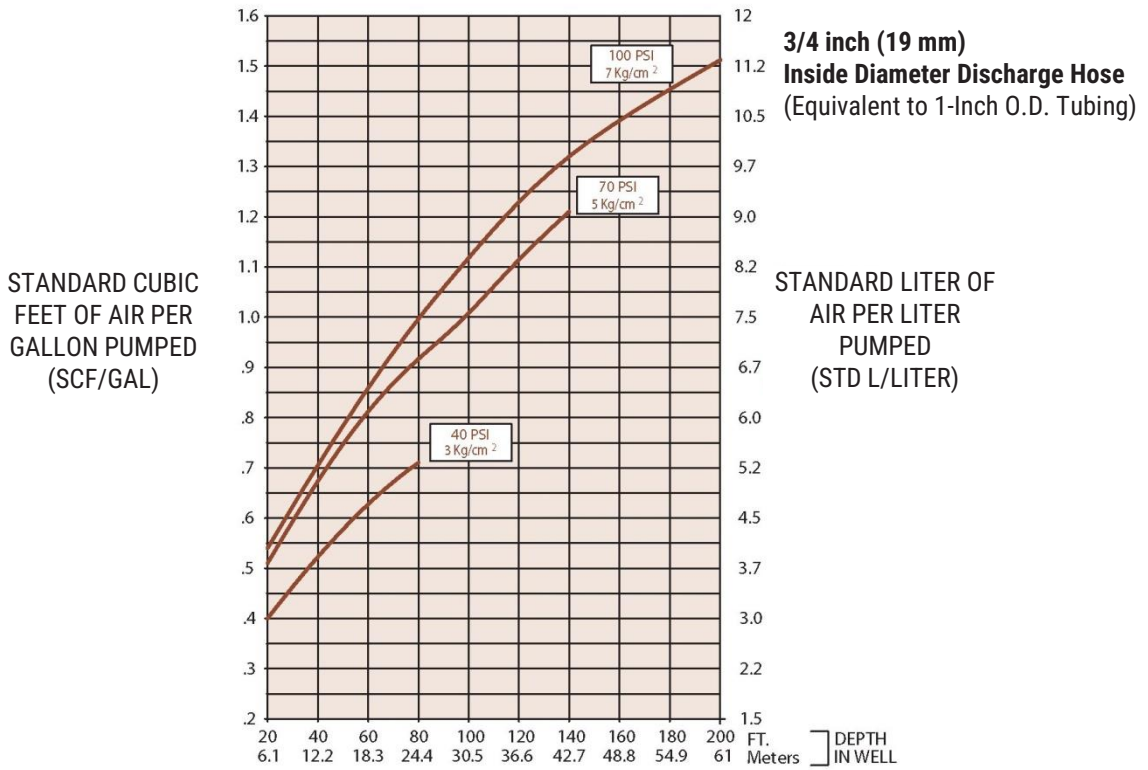

AP4 CLASSIC SHORT LTD ULTRA - BOTTOM LOAD

For Pumps: 303315C

GENERAL SPECIFICATIONS

Liquid Inlet Location:	Bottom
OD:	3.6 in. (9.1 cm)
Length Overall:	39.6 in. (100.6 cm)
Weight:	13 lbs. (7.3 kg)
Max. Flow Rate:	2.5 gpm (9.46 lpm) - See Flow Rate Chart
Pump Volume / Cycle:	0.22 – 0.36 gal (0.83 – 1.36 L)
Min. Actuation Level:	26.7 in. (67.8 cm)

DEPTH AND PRESSURE

Maximum Depth:	250 ft. (76 m)
Air Pressure Range:	5 – 120 psi (0.4 – 8.4 kg/cm ²)
Air Usage:	0.28 – 1.65 scf / gal. (2.09 – 12.34 liters of air /fluid liter) - See Air Usage Chart

CONSTRUCTION MATERIALS

Pump Body:	Fiberglass
Pump Ends:	316 Stainless Steel
Internal Components:	316 Stainless Steel, Viton, PVDF
Tube & Hose Fittings:	316 Stainless Steel
Fitting Type:	Barbs or Quick Connects or Easy Fittings

TUBE & HOSE OPTIONS

Tubing Material:	Nylon
Sizes - Liquid Discharge:	1 in. (25 mm) or 1 – 1/4 in. (32 mm) OD
Pump Air Supply:	1/2 in. (13 mm) OD
Air Exhaust:	5/8 in. (16 mm) OD
Hose Material:	Nitrile
Sizes - Liquid Discharge:	3/4 in. (19 mm) or 1 in. (25 mm) ID
Pump Air Supply:	3/8 in. (9.5 mm) ID
Air Exhaust:	1/2 in. (13 mm) ID

APPLICATION LIMITS

The AP4 is designed to handle the application ranges described below.

Maximum Temperature:	Up to 180°F (82°C)
pH Range:	4 – 12 pH
Salinity:	Up to 270 ppm (150 ppm chloride) at 180°F (82°C) Up to 405 ppm (225 ppm chloride) at 140°F (60°C) Up to 9000 ppm (5000 ppm chloride) at 50°F (10°C)

Flow Rate: 2.5 GPM is the maximum flow rate, found at 90% submergence.

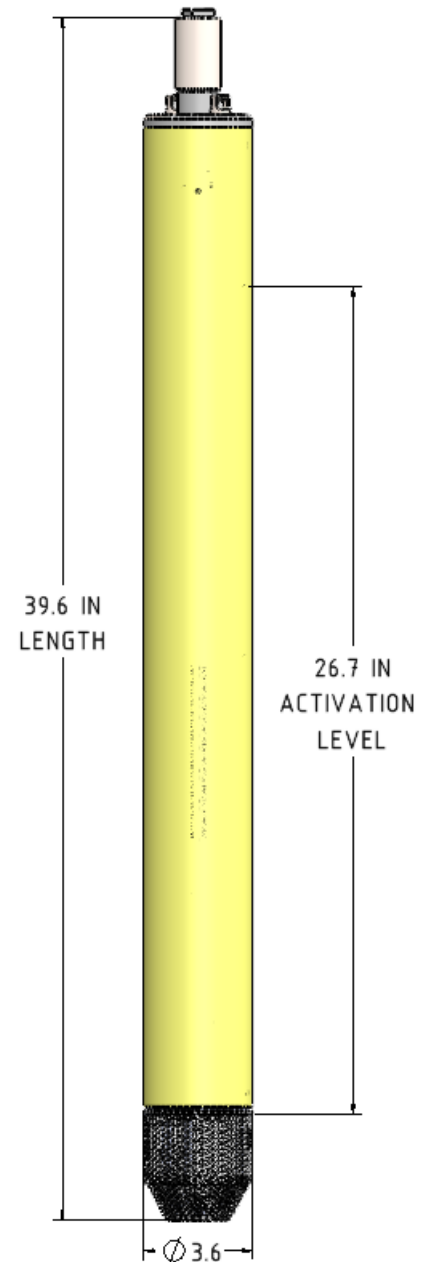

FLOW RATES

**3/4 inch (19mm)
Inside Diameter Discharge Hose
(Equivalent to 1 inch OD Tubing)**

6 in. (15cm) SUBMERGENCE OF PUMP HEAD

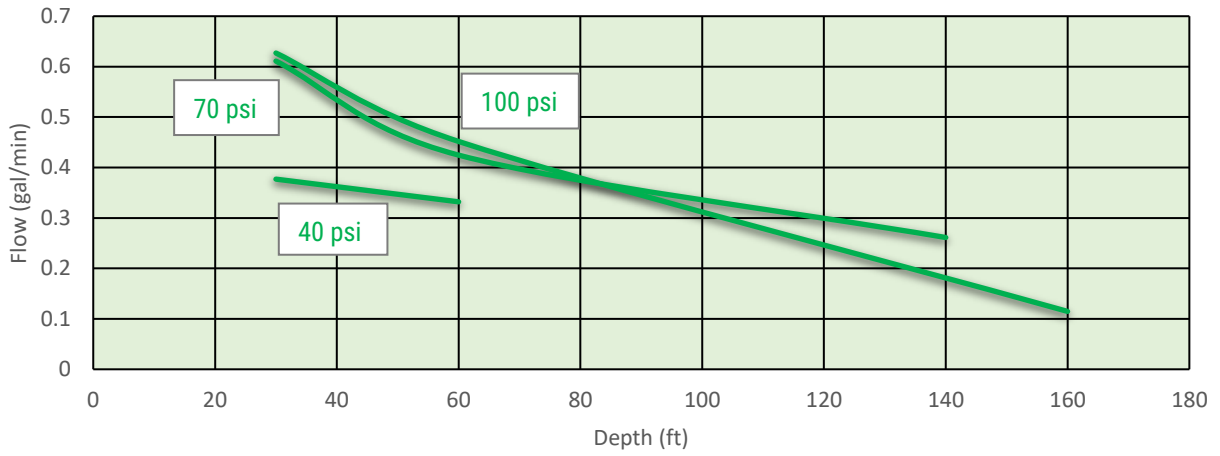

2ft (60cm) SUBMERGENCE OF PUMP HEAD

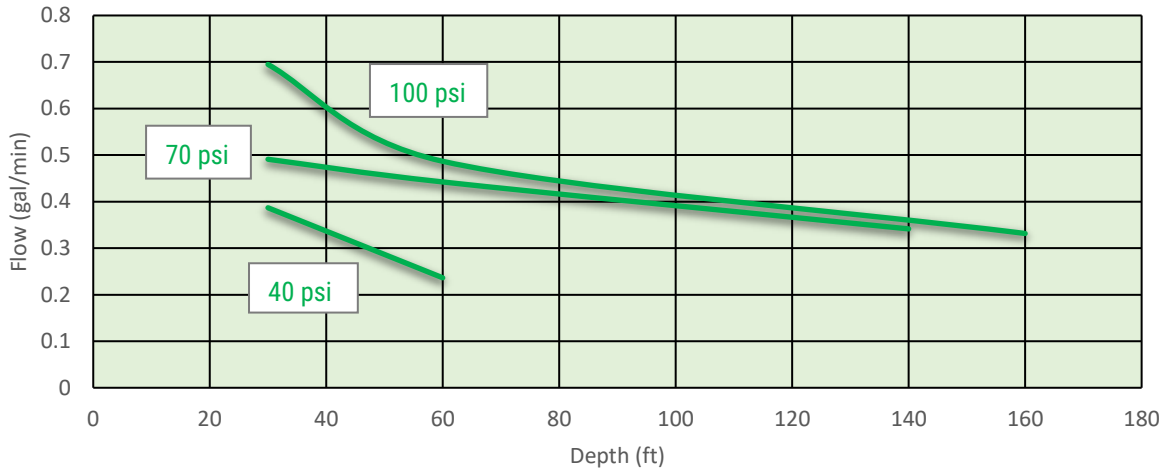

10ft (300CM) SUBMERGENCE OF PUMP HEAD

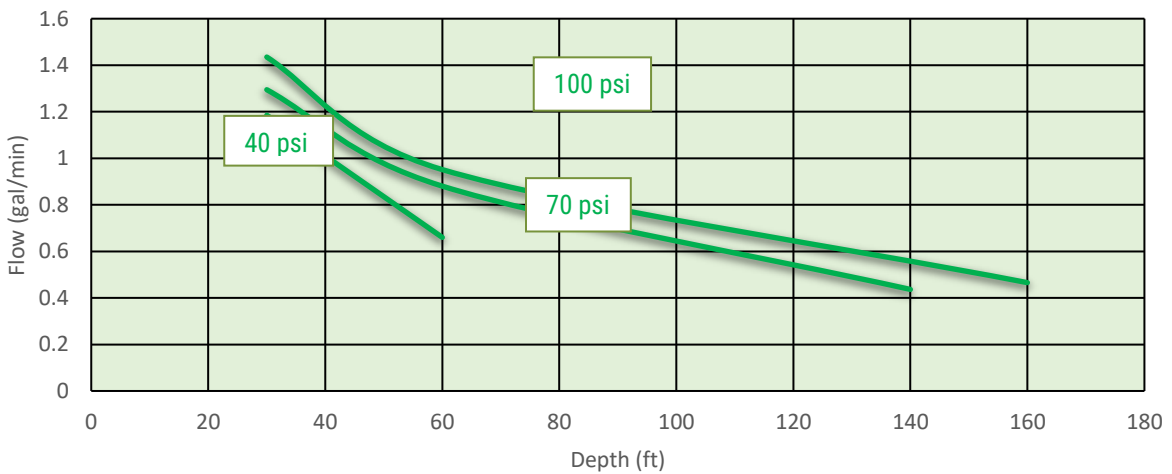

AIR CONSUMPTION

**3/4 inch (19mm)
Inside Diameter Discharge Hose
(Equivalent to 1 inch OD Tubing)**

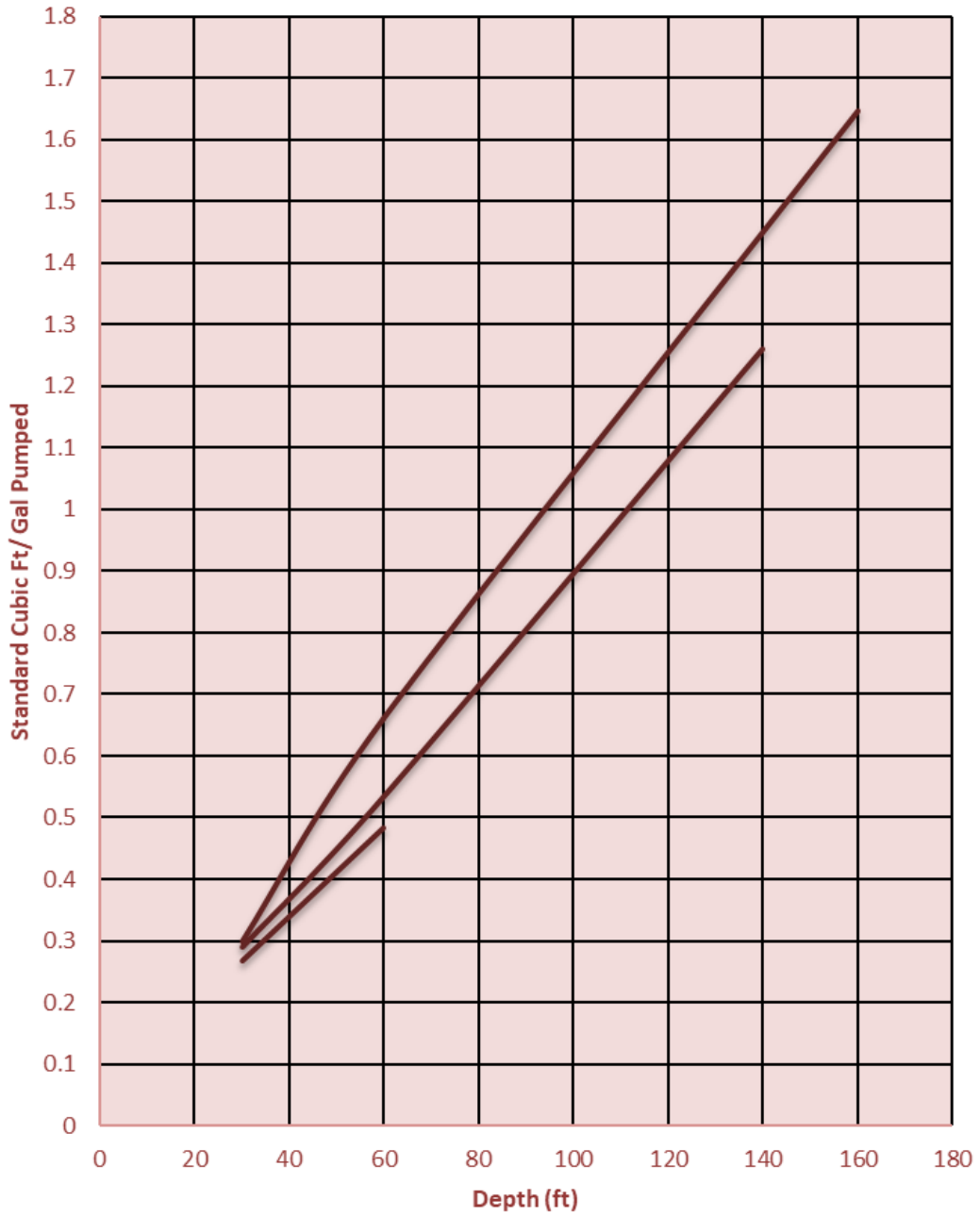

AP4 CLASSIC LONG ULTRA & HIGH TEMP - BOTTOM LOAD

For Pumps: 303223C, 303277C

GENERAL SPECIFICATIONS

Liquid Inlet Location:	Bottom
OD:	3.6 in. (9.1 cm)
Length Overall:	51.6 in. (131.1 cm)
Weight:	16 lbs. (7.3 kg)
Max. Flow Rate:	14 gpm (53 lpm) – See Flow Rate Chart
Pump Volume / Cycle:	0.58 - 0.78 gal (2.2 – 3.0 L)
Min. Actuation Level:	38.4 in. (97.5 cm)

DEPTH AND PRESSURE

Maximum Depth:	250 ft. (76 m)
Air Pressure Range:	5 – 120 psi (0.4 – 8.4 kg/cm ²)
Air Usage:	0.4 – 1.1 scf / gal. (3.0 – 8.5 liters of air / fluid liter) - See Air Usage Chart

CONSTRUCTION MATERIALS

Pump Body:	Fiberglass or Stainless Steel
Pump Ends:	316 Stainless Steel
Internal Components:	316 Stainless Steel, Viton, PVDF
Tube & Hose Fittings:	316 Stainless Steel
Fitting Type:	Barbs or Quick Connects or Easy Fittings

TUBE & HOSE OPTIONS

Tubing Material:	Nylon
Sizes - Liquid Discharge:	1 in. (25 mm) or 1 – 1/4 in. (32 mm) OD
Pump Air Supply:	1/2 in. (13 mm) OD
Air Exhaust:	5/8 in. (16 mm) OD
Hose Material:	Nitrile
Sizes - Liquid Discharge:	3/4 in. (19 mm) or 1 in. (25 mm) ID
Pump Air Supply:	3/8 in. (9.5 mm) ID
Air Exhaust:	1/2 in. (13 mm) ID

APPLICATION LIMITS

The AP4 is designed to handle the application ranges described below.

Maximum Temperature:	Up to 250°F (121°C) with certain models
pH Range:	2 – 12 pH
Salinity:	Up to 270 ppm (150 ppm chloride) at 180°F (82°C) Up to 405 ppm (225 ppm chloride) at 140°F (60°C) Up to 9000 ppm (5000 ppm chloride) at 50°F (10°C)

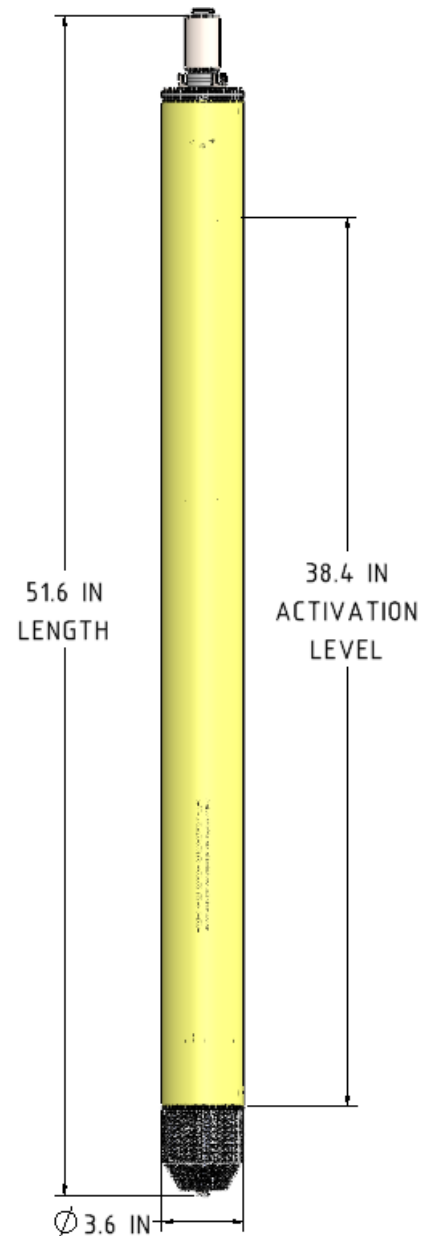

FLOW RATES

3/4 inch (19mm)
Inside Diameter Discharge Hose
 (Equivalent to 1 inch OD Tubing)

1 inch (25mm)
Inside Diameter Discharge Hose
 (Equivalent to 1.25 inch OD Tubing)

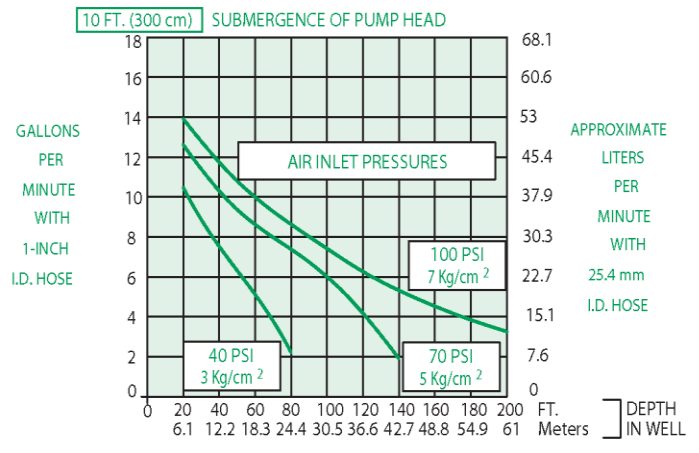
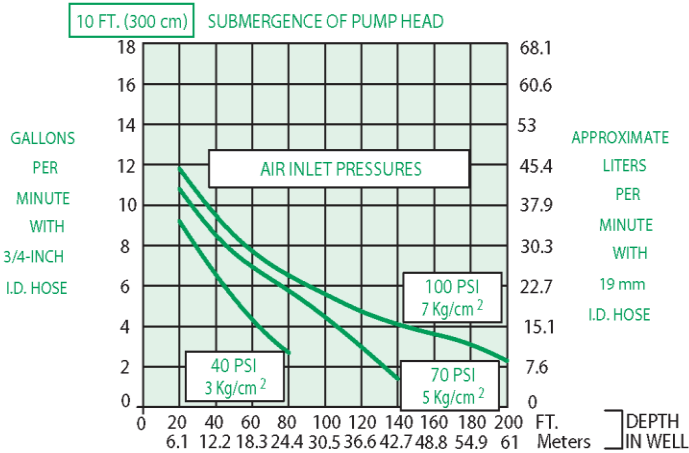
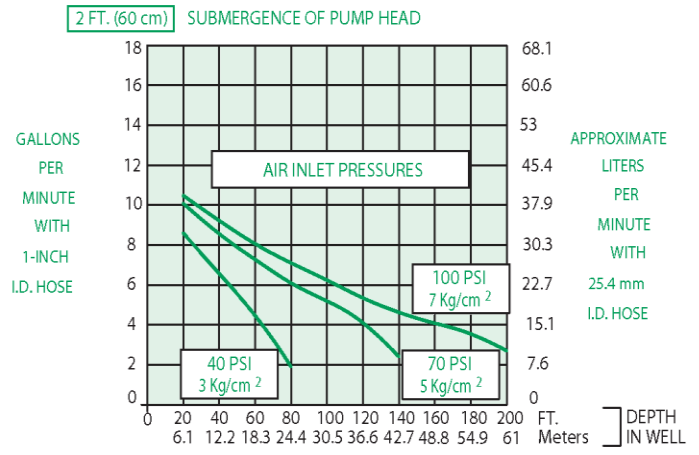
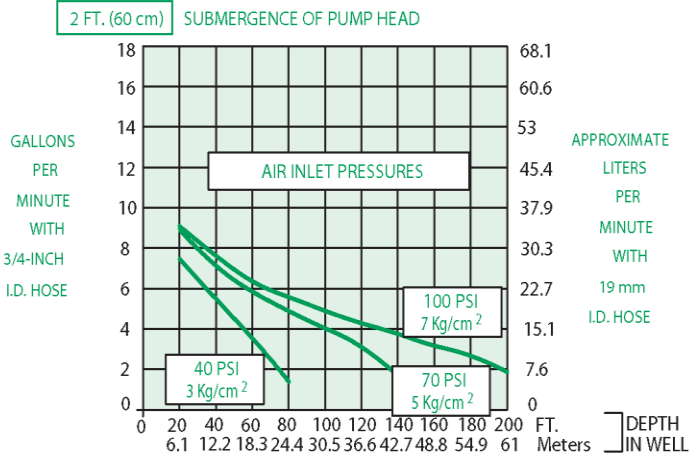
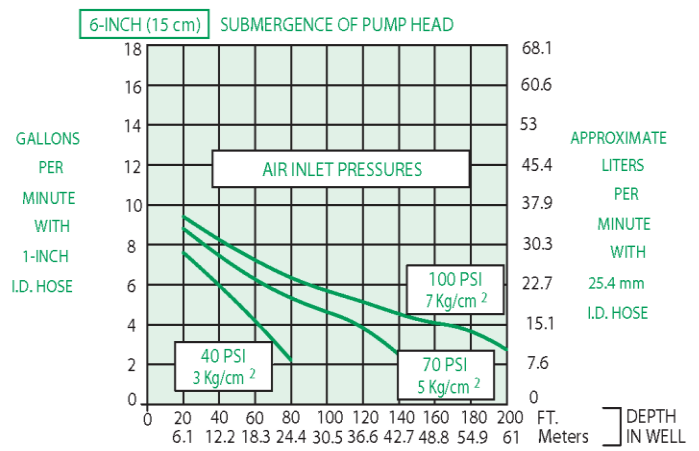
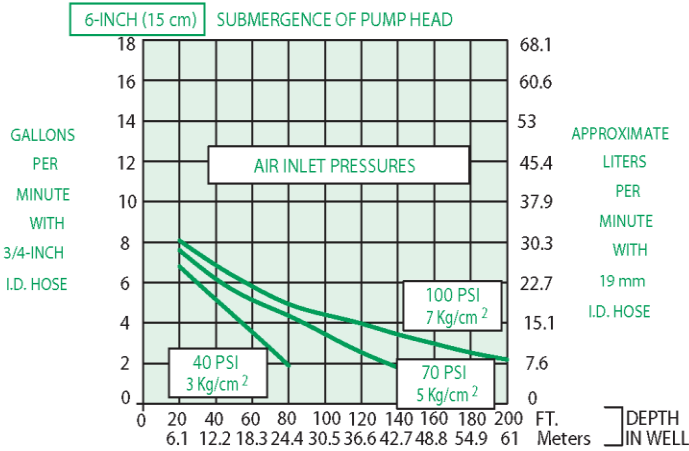

AIR CONSUMPTION

STANDARD CUBIC FEET OF AIR PER GALLON PUMPED (SCF/GAL)

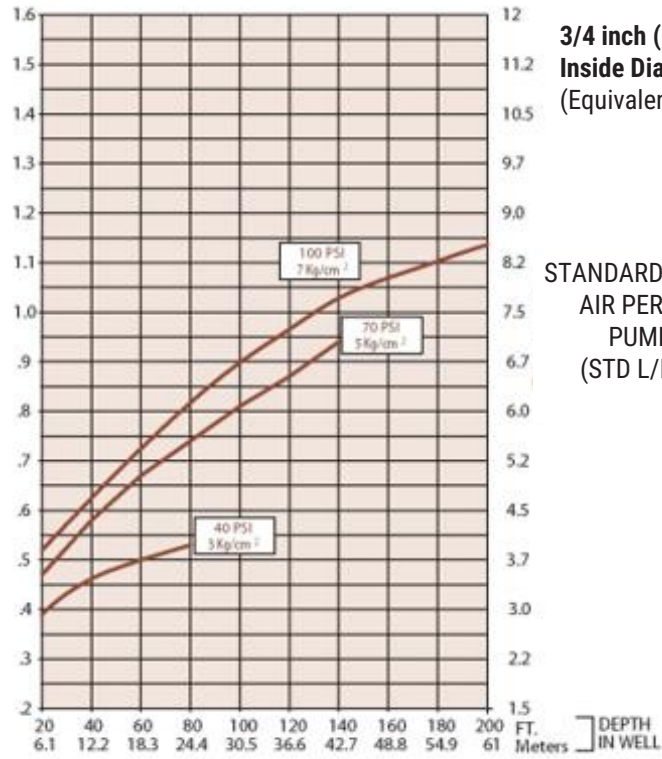

STANDARD LITER OF AIR PER LITER PUMPED (STD L/LITER)

STANDARD CUBIC FEET OF AIR PER GALLON PUMPED (SCF/GAL)

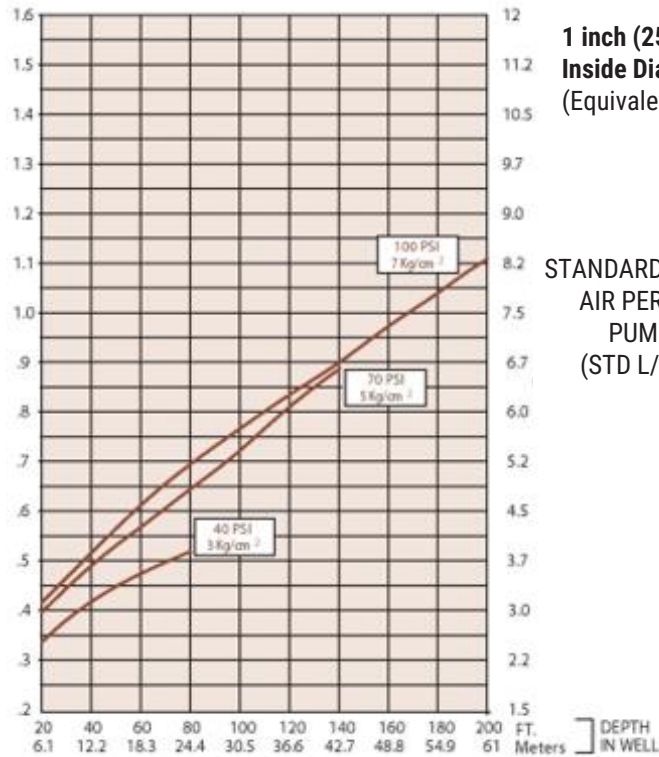

STANDARD LITER OF AIR PER LITER PUMPED (STD L/LITER)

AP4 CLASSIC LOW DRAW DOWN AGGRESSIVE FLUIDS - TOP LOAD

Model Numbers: 303107C

GENERAL SPECIFICATIONS

Liquid Inlet Location:	Top
OD:	3.6 in. (9.1 cm)
Length Overall:	29.2 in. (74.2 cm)
Weight:	9.8 lbs. (4.4 kg)
Max. Flow Rate:	6.4 gpm (24 lpm) - See Flow Rate Chart
Pump Volume / Cycle:	0.11 - 0.16 gal (0.42 - 0.61 L)
Min. Actuation Level:	26.8 in. (68.1 cm)

DEPTH AND PRESSURE

Maximum Depth:	250 ft. (76 m)
Air Pressure Range:	5 - 120 psi (0.4 - 8.4 kg/cm ²)
Air Usage:	0.35 - 1.5 scf / gal. (2.4 - 11.3 liters of air / fluid liter) - See Air Usage Chart

CONSTRUCTION MATERIALS

Pump Body:	Fiberglass
Pump Ends:	316 Stainless Steel
Internal Components:	316 Stainless Steel, Viton, PVDF
Tube & Hose Fittings:	316 Stainless Steel
Fitting Type:	Barbs or Quick Connects or Easy Fittings

TUBE & HOSE OPTIONS

Tubing Material:	Nylon
Sizes - Liquid Discharge:	1 in. (25 mm) or 1 - 1/4 in. (32 mm) OD
Pump Air Supply:	1/2 in. (13 mm) OD
Air Exhaust:	5/8 in. (16 mm) OD
Hose Material:	Nitrile
Sizes - Liquid Discharge:	3/4 in. (19 mm) or 1 in. (25 mm) ID
Pump Air Supply:	3/8 in. (9.5 mm) ID
Air Exhaust:	1/2 in. (13 mm) ID

APPLICATION LIMITS

The AP4 is designed to handle the application ranges described below.

Maximum Temperature:	Up to 180°F (82°C) with certain models
pH Range:	4 - 12 pH
Salinity:	Up to 270 ppm (150 ppm chloride) at 180°F (82°C) Up to 405 ppm (225 ppm chloride) at 140°F (60°C) Up to 9000 ppm (5000 ppm chloride) at 50°F (10°C)

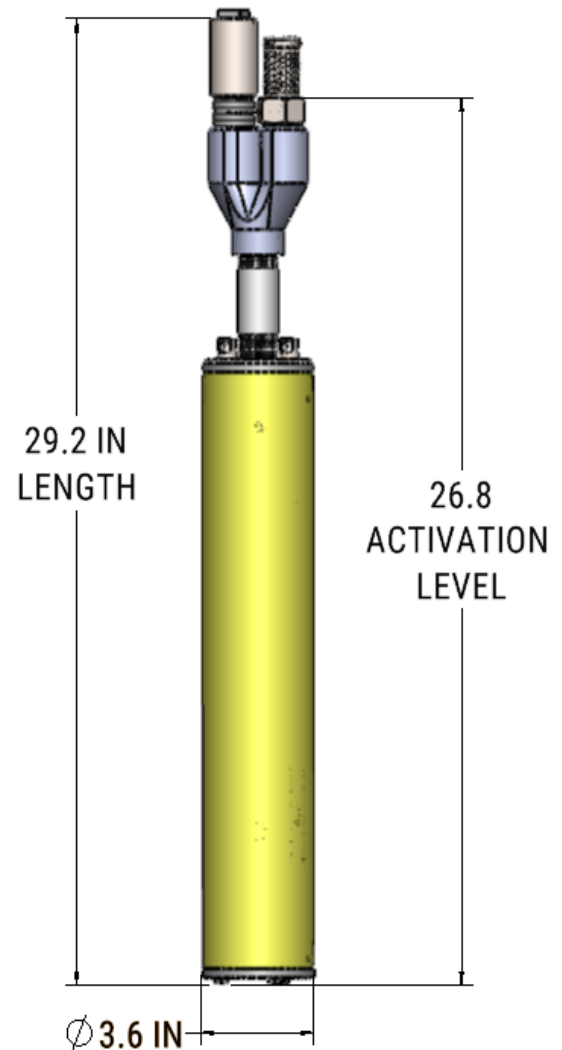

FLOW RATES

Flow rates may vary with site conditions.

3/4 inch (19mm)
Inside Diameter Discharge Hose
 (Equivalent to 1 inch OD Tubing)

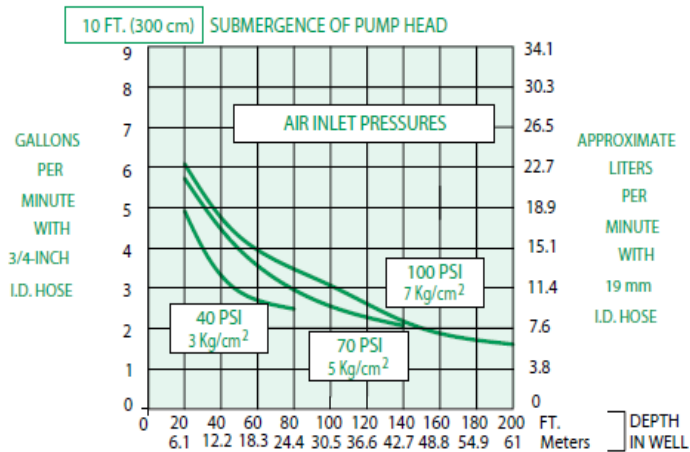
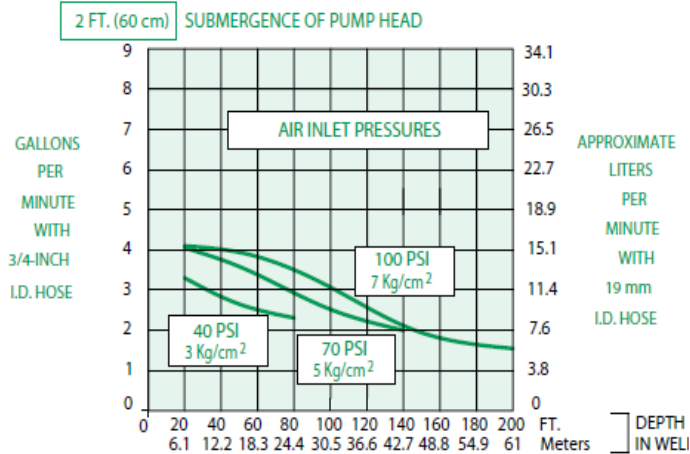
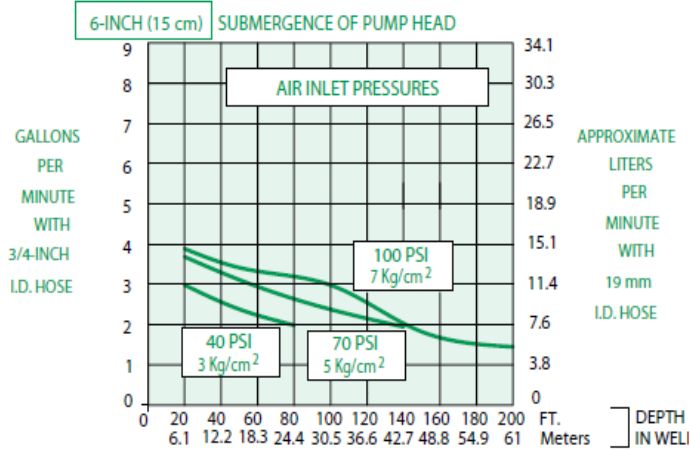

1 inch (25mm)
Inside Diameter Discharge Hose
 (Equivalent to 1.25 inch OD Tubing)

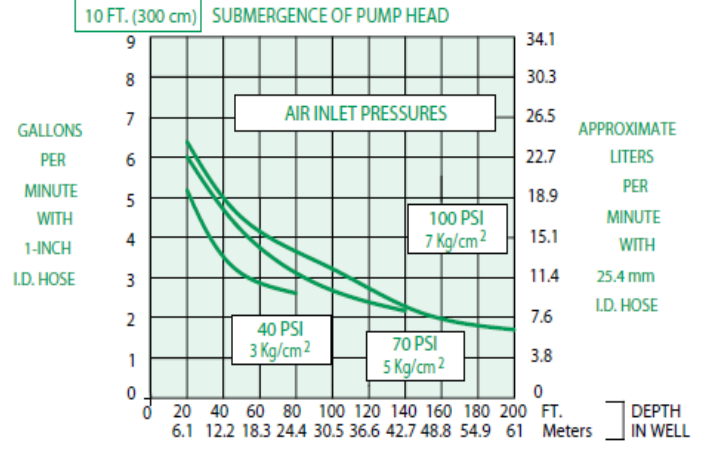
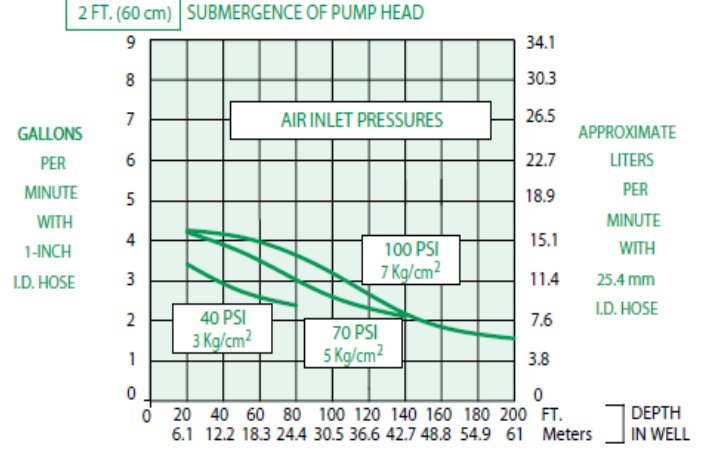
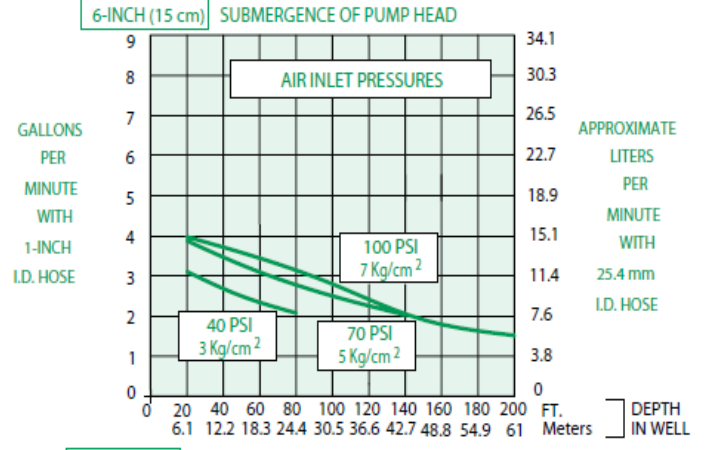

AIR CONSUMPTION

STANDARD CUBIC FEET OF AIR PER GALLON PUMPED (SCF/GAL)

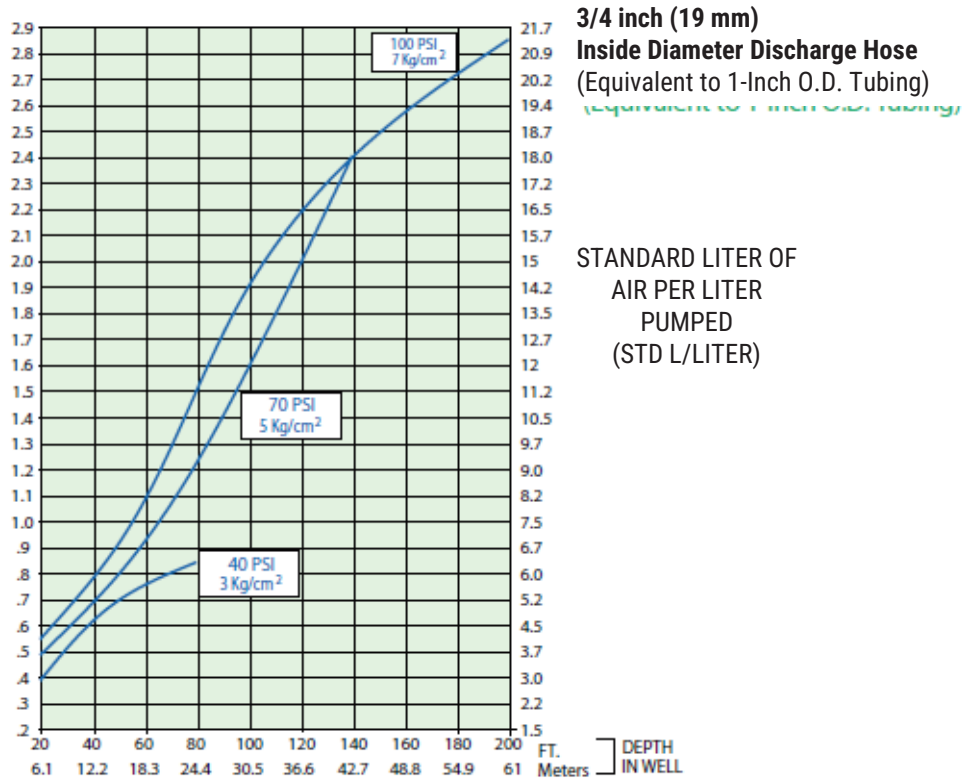

STANDARD LITER OF AIR PER LITER PUMPED (STD L/LITER)

STANDARD CUBIC FEET OF AIR PER GALLON PUMPED (SCF/GAL)

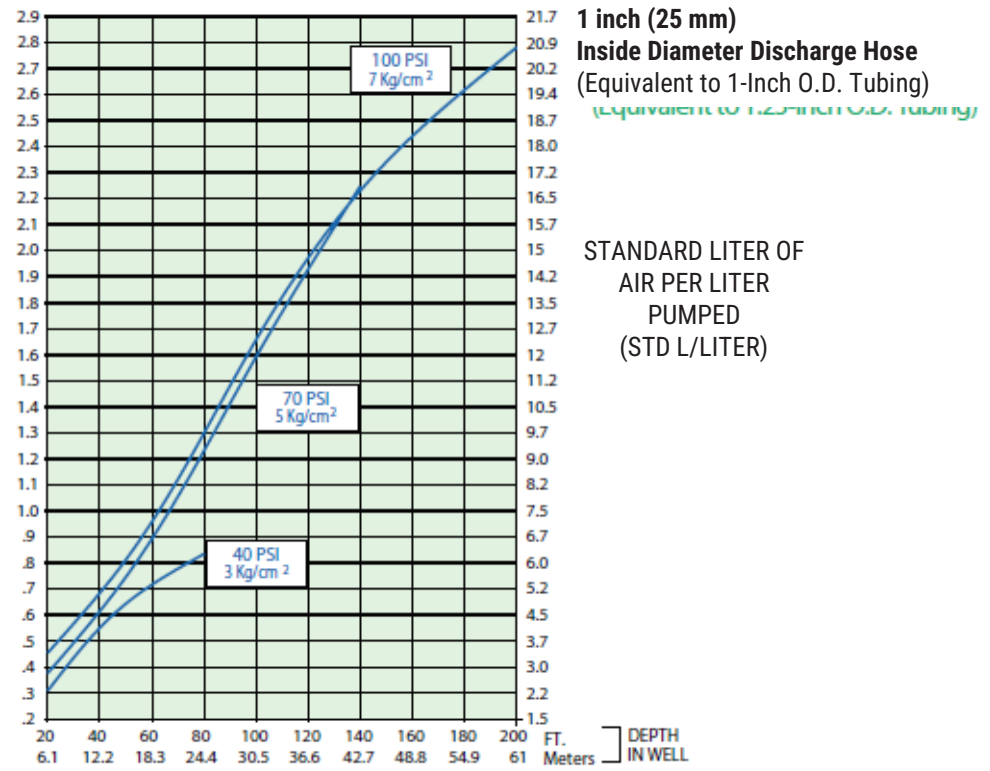

STANDARD LITER OF AIR PER LITER PUMPED (STD L/LITER)

AP4 CLASSIC SHORT ULTRA - TOP LOAD

For Pumps: 303243C

GENERAL SPECIFICATIONS

Liquid Inlet Location:	Top
OD:	3.6 in. (9.1 cm)
Length Overall:	43.8 in. (111.3 cm)
Weight:	17 lbs. (7.8 kg)
Max. Flow Rate:	9 gpm (34 lpm) - See Flow Rate Chart
Pump Volume / Cycle:	0.22 – 0.36 gal (.83 – 1.36 L)
Min. Actuation Level:	41 in. (104.1 cm)

DEPTH AND PRESSURE

Maximum Depth:	250 ft. (76 m)
Air Pressure Range:	5 – 120 psi (0.4 – 8.4 kg/cm ²)
Air Usage:	0.35 – 1.5 scf / gal. (2.4 – 11.3 liters of air / fluid liter) - See Air Usage Chart

CONSTRUCTION MATERIALS

Pump Body:	Fiberglass
Pump Ends:	316 Stainless Steel
Internal Components:	316 Stainless Steel, Viton, PVDF
Tube & Hose Fittings:	316 Stainless Steel
Fitting Type:	Barbs or Quick Connects or Easy Fittings

TUBE & HOSE OPTIONS

Tubing Material:	Nylon
Sizes - Liquid Discharge:	1 in. (25 mm) or 1 – 1/4 in. (32 mm) OD
Pump Air Supply:	1/2 in. (13 mm) OD
Air Exhaust:	5/8 in. (16 mm) OD
Hose Material:	Nitrile
Sizes - Liquid Discharge:	3/4 in. (19 mm) or 1 in. (25 mm) ID
Pump Air Supply:	3/8 in. (9.5 mm) ID
Air Exhaust:	1/2 in. (13 mm) ID

APPLICATION LIMITS

The AP4 is designed to handle the application ranges described below.

Maximum Temperature:	Up to 180°F (82°C)
pH Range:	4 – 12 pH
Salinity:	Up to 270 ppm (150 ppm chloride) at 180°F (82°C) Up to 405 ppm (225 ppm chloride) at 140°F (60°C) Up to 9000 ppm (5000 ppm chloride) at 50°F (10°C)

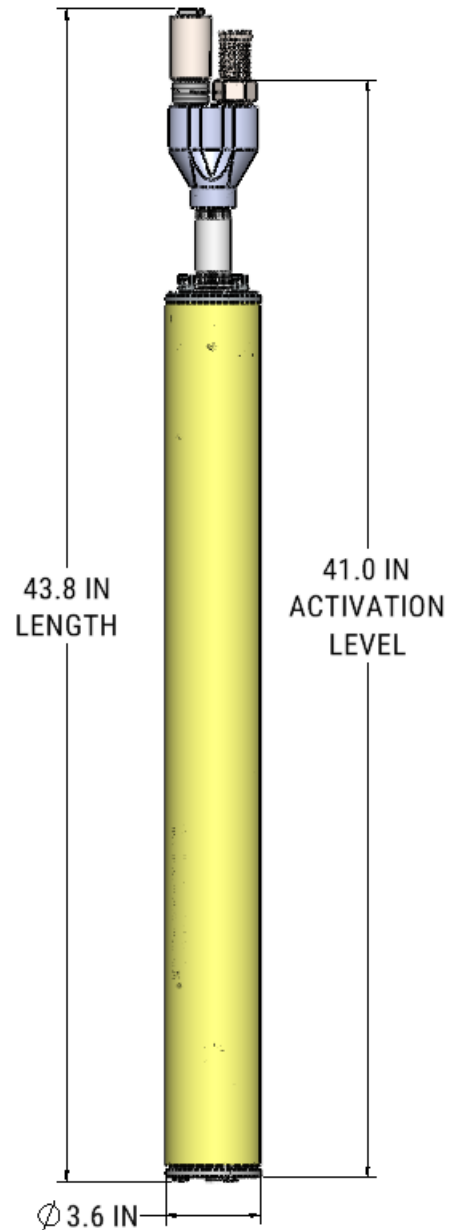

FLOW RATES

Flow rates may vary with site conditions.

¾ inch (19mm)
Inside Diameter Discharge Hose
 (Equivalent to 1 inch OD Tubing)

1 inch (25mm)
Inside Diameter Discharge Hose
 (Equivalent to 1.25 inch OD Tubing)

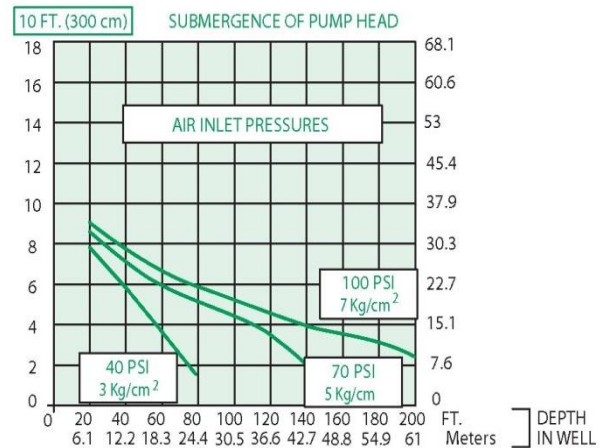
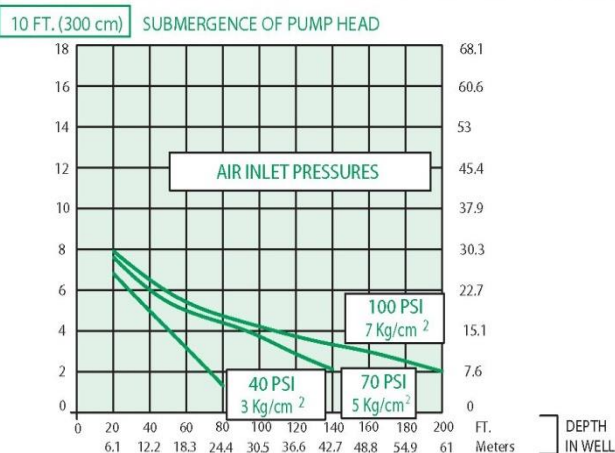
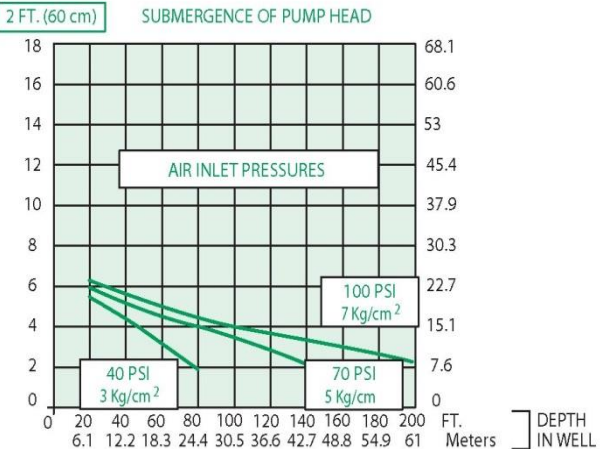
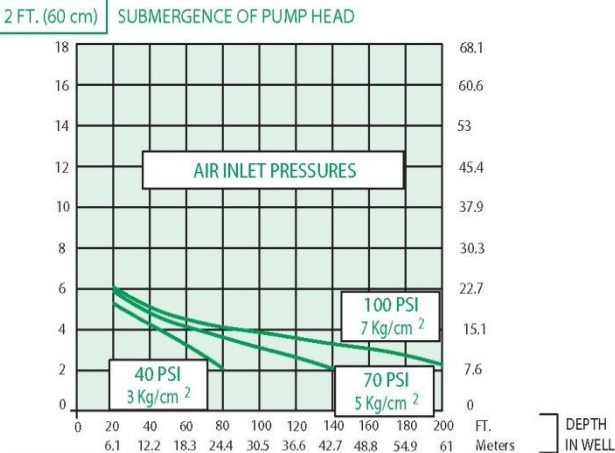
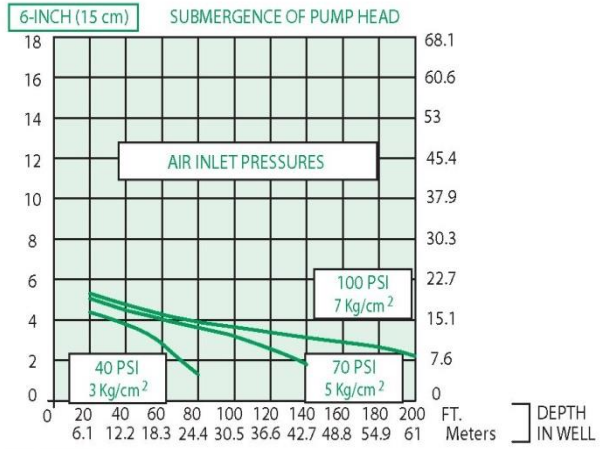
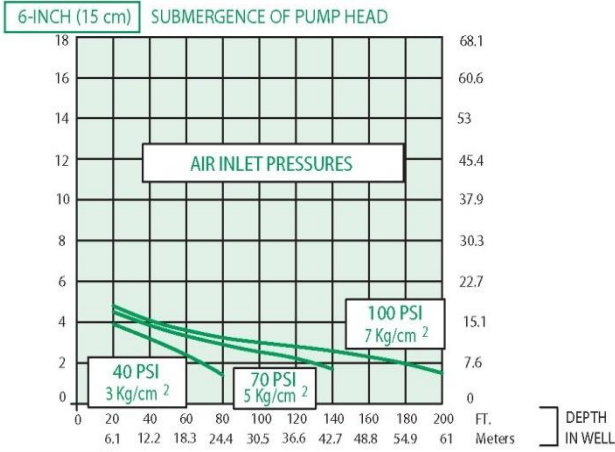

AIR CONSUMPTION

STANDARD CUBIC FEET OF AIR PER GALLON PUMPED (SCF/GAL)

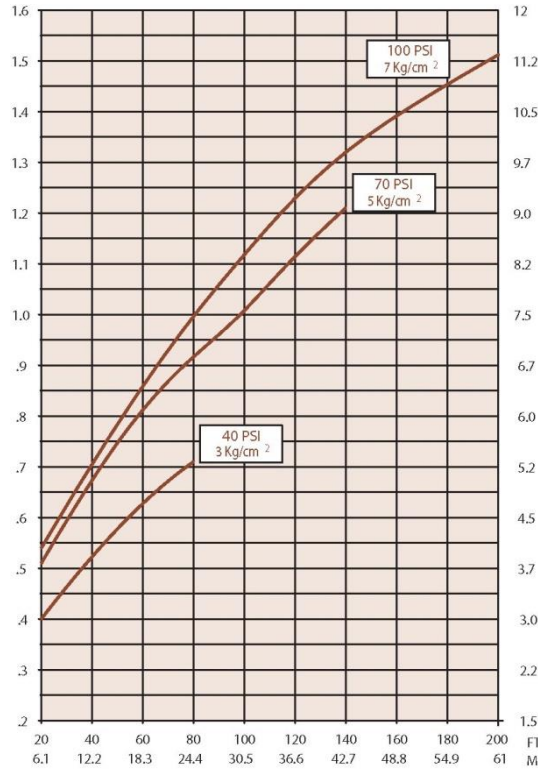

3/4 inch (19 mm)
Inside Diameter Discharge Hose
 (Equivalent to 1-Inch O.D. Tubing)

STANDARD LITER OF AIR PER LITER PUMPED (STD L/LITER)

STANDARD CUBIC FEET OF AIR PER GALLON PUMPED (SCF/GAL)

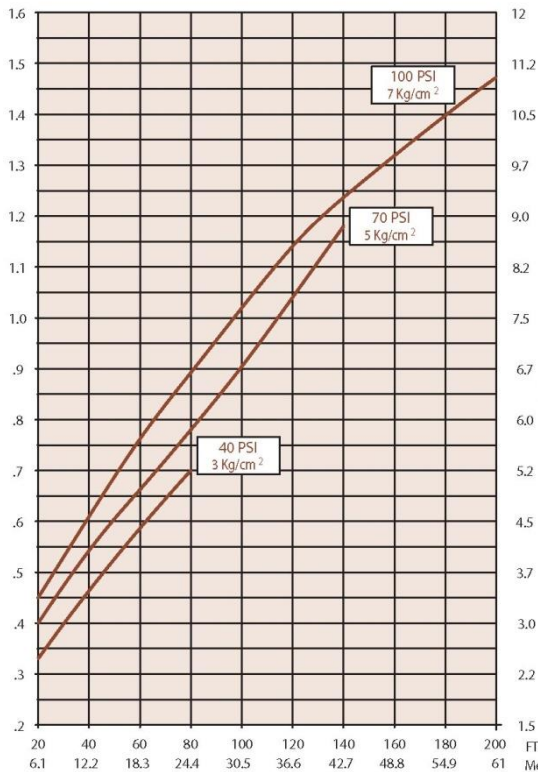

1 inch (25 mm)
Inside Diameter Discharge Hose
 (Equivalent to 1-Inch O.D. Tubing)

STANDARD LITER OF AIR PER LITER PUMPED (STD L/LITER)

AP4 CLASSIC LONG ULTRA - TOP LOAD

For Pumps: 303244C

GENERAL SPECIFICATIONS

Liquid Inlet Location:	Top
OD:	3.6 in. (9.1 cm)
Length Overall:	55.1 in. (140.0 cm)
Weight:	18 lbs. (8.7 kg)
Max. Flow Rate:	10 gpm (38 lpm) - See Flow Rate Chart
Pump Volume / Cycle:	0.58 – 0.78 gal (2.2 – 3.0 L)
Min. Actuation Level:	52.5 in. (133.4 cm)

DEPTH AND PRESSURE

Maximum Depth:	250 ft. (76 m)
Air Pressure Range:	5 – 120 psi (0.4 – 8.4 kg/cm ²)
Air Usage:	0.35 – 1.5 scf / gal. (2.4 – 11.3 liters of air / fluid liter) - See Air Usage Chart

CONSTRUCTION MATERIALS

Pump Body:	Fiberglass
Pump Ends:	316 Stainless Steel
Internal Components:	316 Stainless Steel, Viton, PVDF
Tube & Hose Fittings:	316 Stainless Steel
Fitting Type:	Barbs or Quick Connects or Easy Fittings

TUBE & HOSE OPTIONS

Tubing Material:	Nylon
Sizes - Liquid Discharge:	1 in. (25 mm) or 1 – 1/4 in. (32 mm) OD
Pump Air Supply:	1/2 in. (13 mm) OD
Air Exhaust:	5/8 in. (16 mm) OD
Hose Material:	Nitrile
Sizes - Liquid Discharge:	3/4 in. (19 mm) or 1 in. (25 mm) ID
Pump Air Supply:	3/8 in. (9.5 mm) ID
Air Exhaust:	1/2 in. (13 mm) ID

APPLICATION LIMITS

The AP4 is designed to handle the application ranges described below.

Maximum Temperature:	Up to 180°F (82°C)
pH Range:	4 – 12 pH
Salinity:	Up to 270 ppm (150 ppm chloride) at 180°F (82°C) Up to 405 ppm (225 ppm chloride) at 140°F (60°C) Up to 9000 ppm (5000 ppm chloride) at 50°F (10°C)

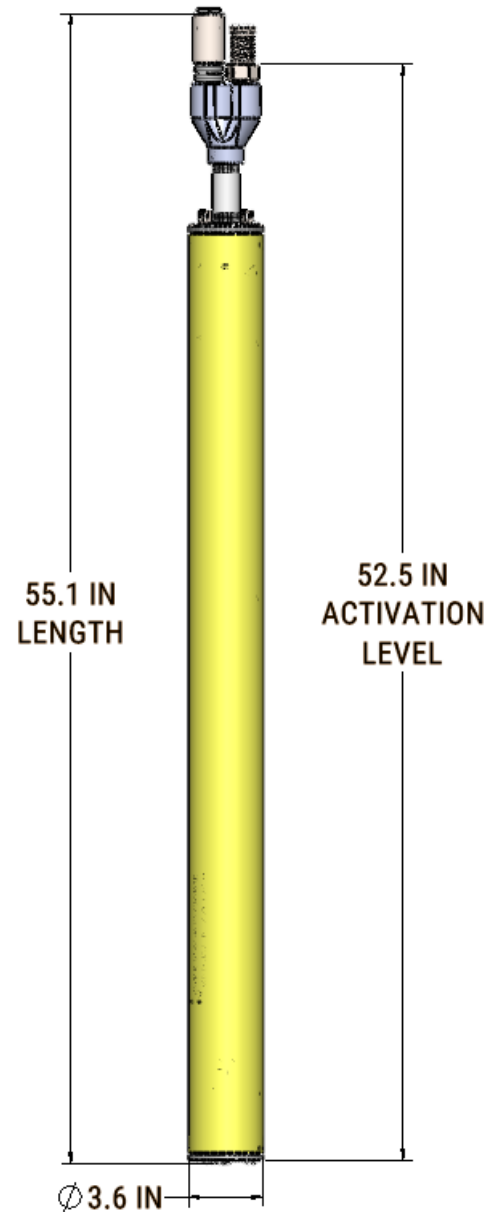

FLOW RATES

Flow rates may vary with site conditions.

**¾ inch (19mm)
Inside Diameter Discharge Hose
(Equivalent to 1 inch OD Tubing)**

**1 inch (25mm)
Inside Diameter Discharge Hose
(Equivalent to 1.25 inch OD Tubing)**

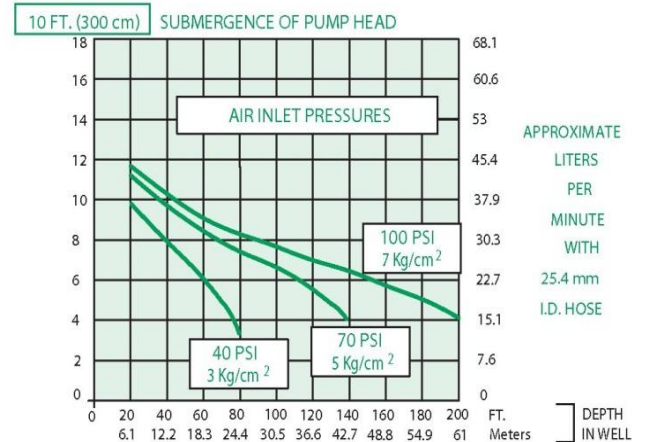
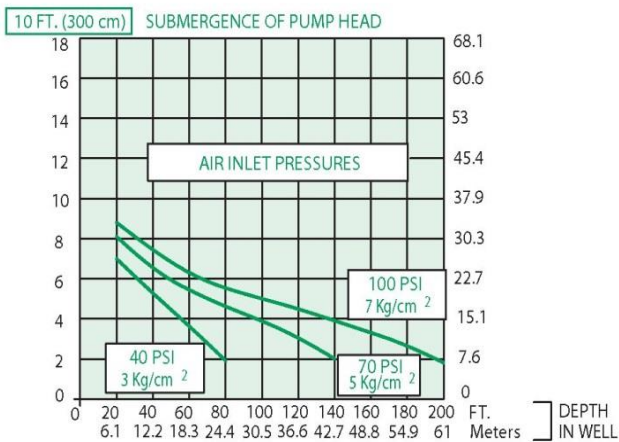
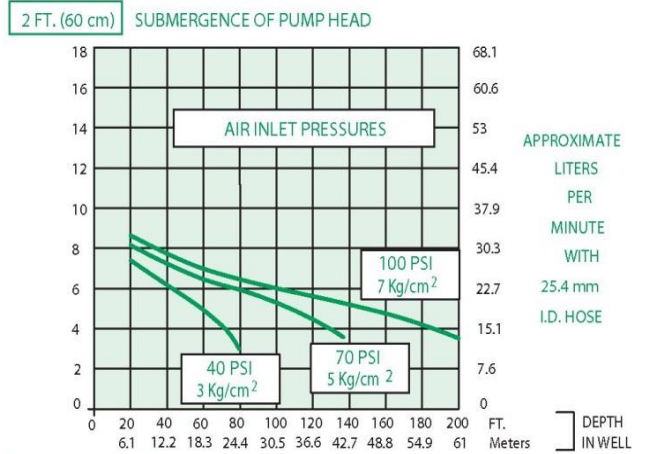
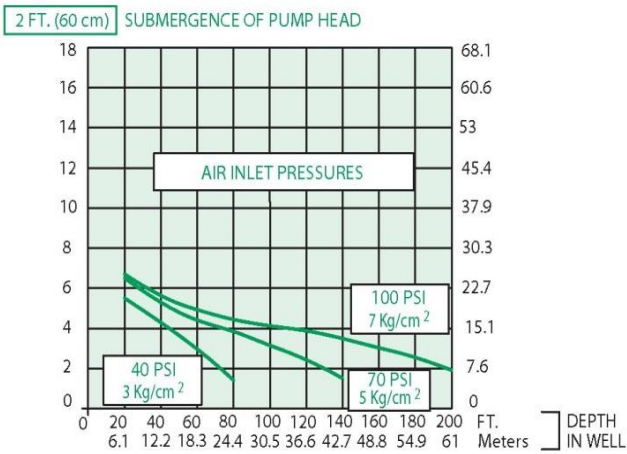
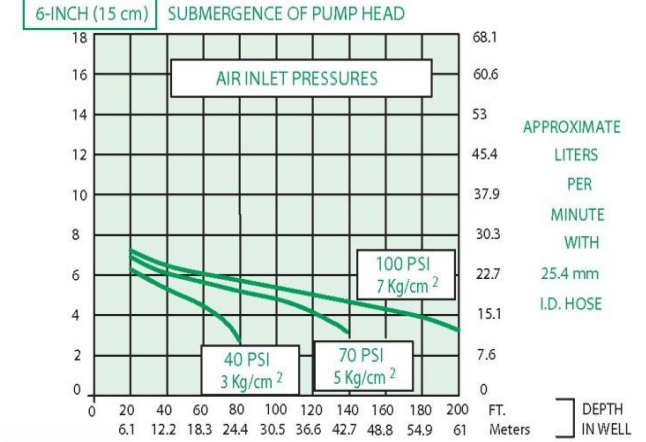
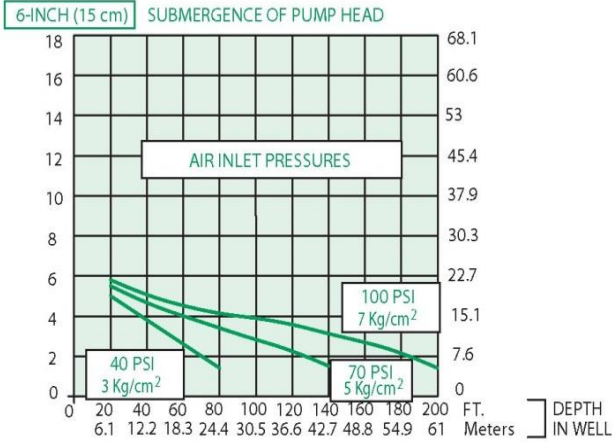

AIR CONSUMPTION

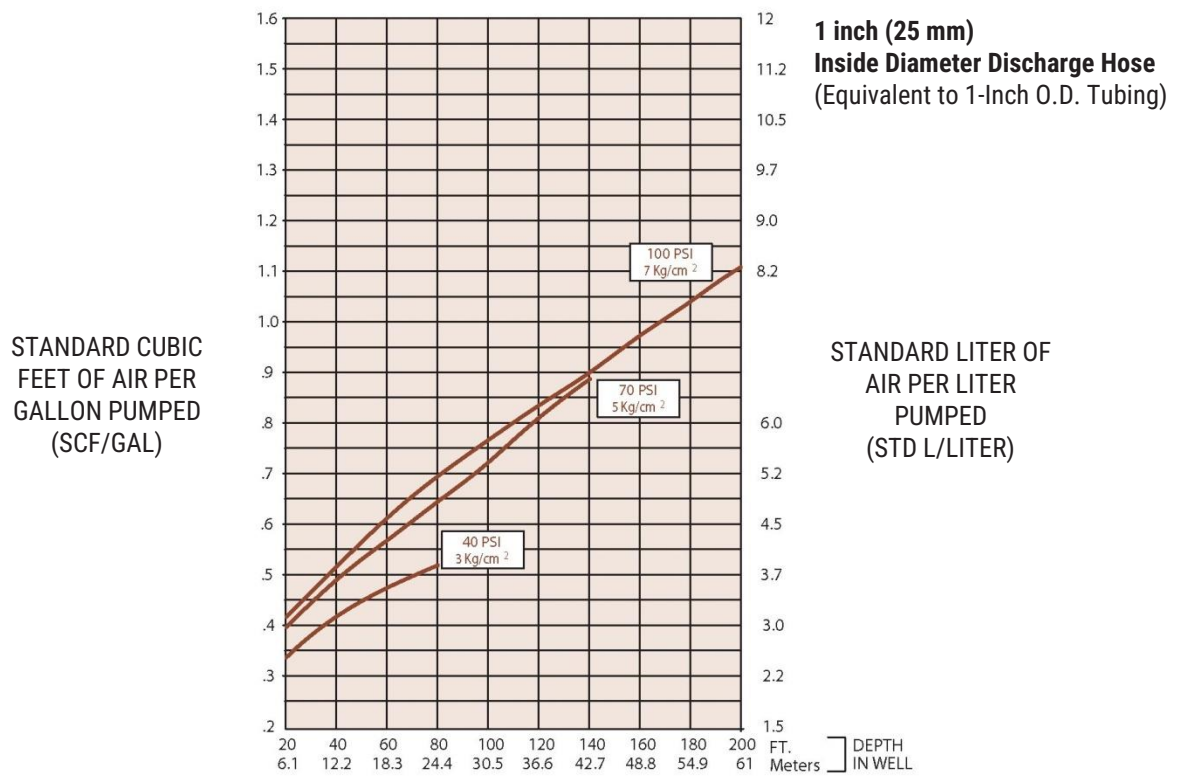
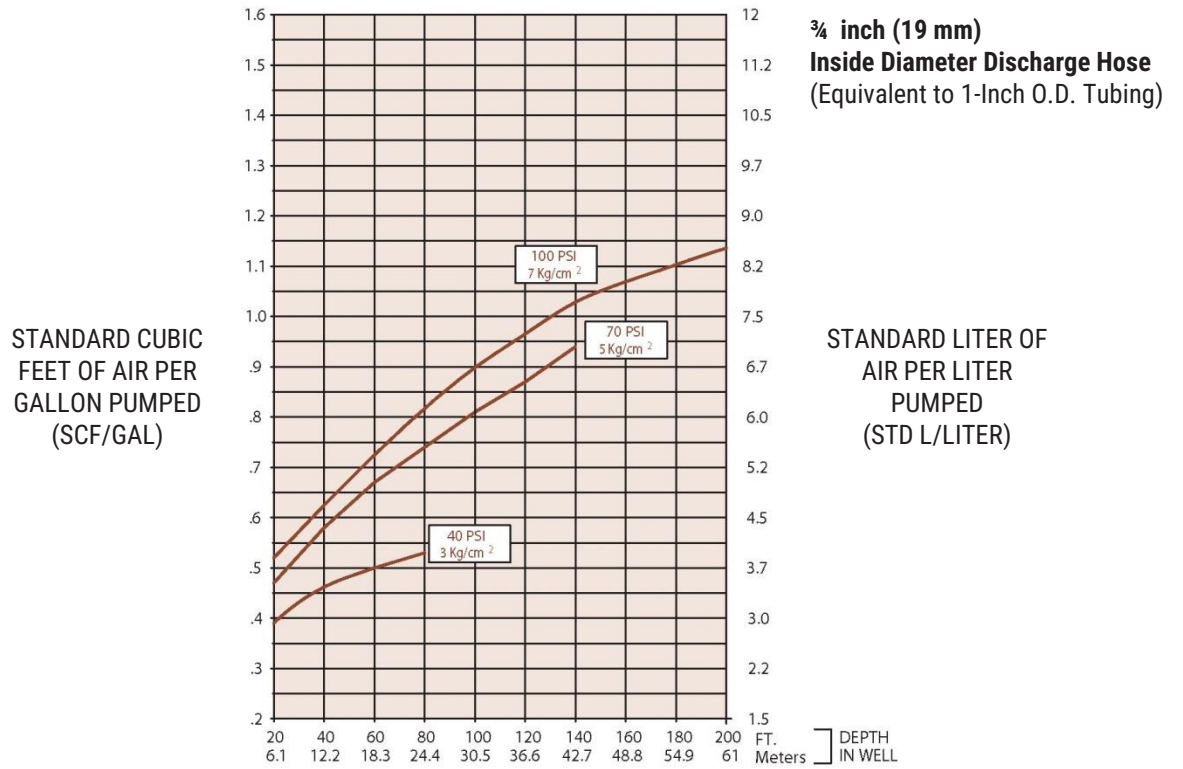

AP4.5 CLASSIC ULTRA & HIGH TEMP. - BOTTOM LOAD

For Pumps: 303269CX, 303312CX

GENERAL SPECIFICATIONS

Liquid Inlet Location:	Bottom
OD:	4.6 in. (11.7 cm)
Length Overall:	39.7 in. (100.8 cm)
Weight:	17.8 lbs. (8.7 kg)
Max. Flow Rate:	13 gpm (38 lpm) - See Flow Rate Chart
Pump Volume / Cycle:	0.45 – 0.55 gal (1.7 – 2.08 L)
Min. Actuation Level:	26.7 in. (67.8 cm)

DEPTH AND PRESSURE

Maximum Depth:	250 ft. (76 m)
Air Pressure Range:	5 – 120 psi (0.4 – 8.4 kg/cm ²)
Air Usage:	0.4 – 1.1 scf / gal. (3.0 – 8.4 liters of air / fluid liter) - See Air Usage Chart

CONSTRUCTION MATERIALS

Pump Body:	Fiberglass or Stainless Steel
Pump Ends:	316 Stainless Steel
Internal Components:	316 Stainless Steel, Viton, PVDF
Tube & Hose Fittings:	316 Stainless Steel
Fitting Type:	Barbs or Quick Connects or Easy Fittings

TUBE & HOSE OPTIONS

Tubing Material:	Nylon
Sizes - Liquid Discharge:	1 in. (25 mm) or 1 – 1/4 in. (32 mm) OD
Pump Air Supply:	1/2 in. (13 mm) OD
Air Exhaust:	5/8 in. (16 mm) OD
Hose Material:	Nitrile
Sizes - Liquid Discharge:	3/4 in. (19 mm) or 1 in. (25 mm) ID
Pump Air Supply:	3/8 in. (9.5 mm) ID
Air Exhaust:	1/2 in. (13 mm) ID

APPLICATION LIMITS

The AP4 is designed to handle the application ranges described below.

Maximum Temperature:	Up to 250°F (121°C) with certain models
pH Range:	2 – 12 pH
Salinity:	Up to 270 ppm (150 ppm chloride) at 180°F (82°C) Up to 405 ppm (225 ppm chloride) at 140°F (60°C) Up to 9000 ppm (5000 ppm chloride) at 50°F (10°C)

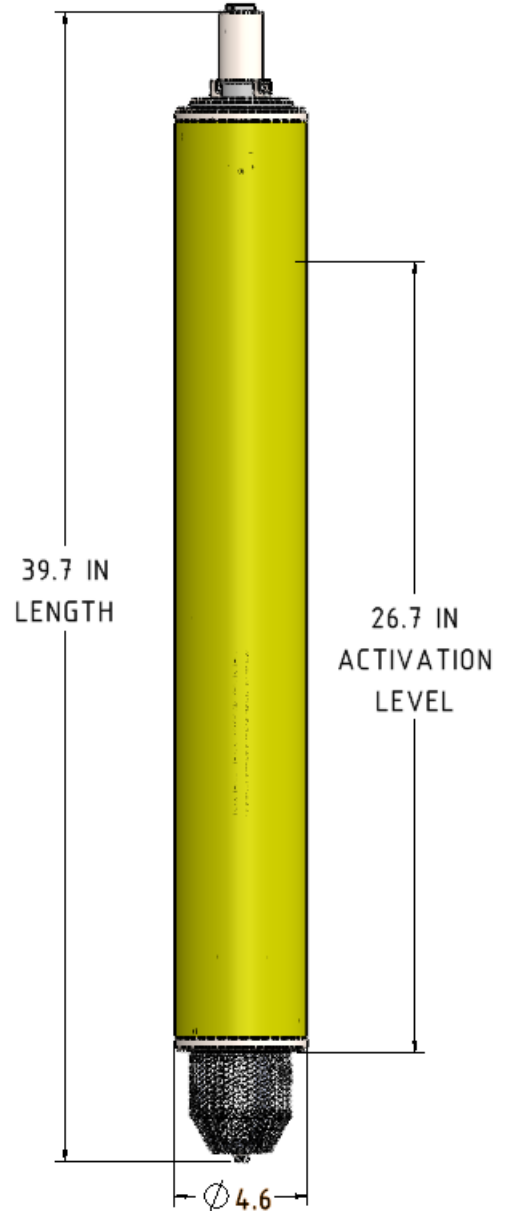

COMPONENT IDENTIFICATION

REMOVE BEFORE INSTALLING FITTINGS

FIGURE 1	
ITEM	NAME
A	DISCHARGE CHECK BALL
B	SUPPORT CHAIN
C	DISCRHAGE CHECK HOUSING
D	CASING O-RING
E	FLOAT
F	CASING
G	FRAME
H	XTREME AUGER
J	SPIDER
K	INLET CHECK
L	INLET
M	INLET BOLTS
N	SCREEN
P	SCREEN HARDWARE
Q	CONTROL ROD
R	SLIDING STOP
S	SPRING
T	SPRING CUP
U	HAIR PIN

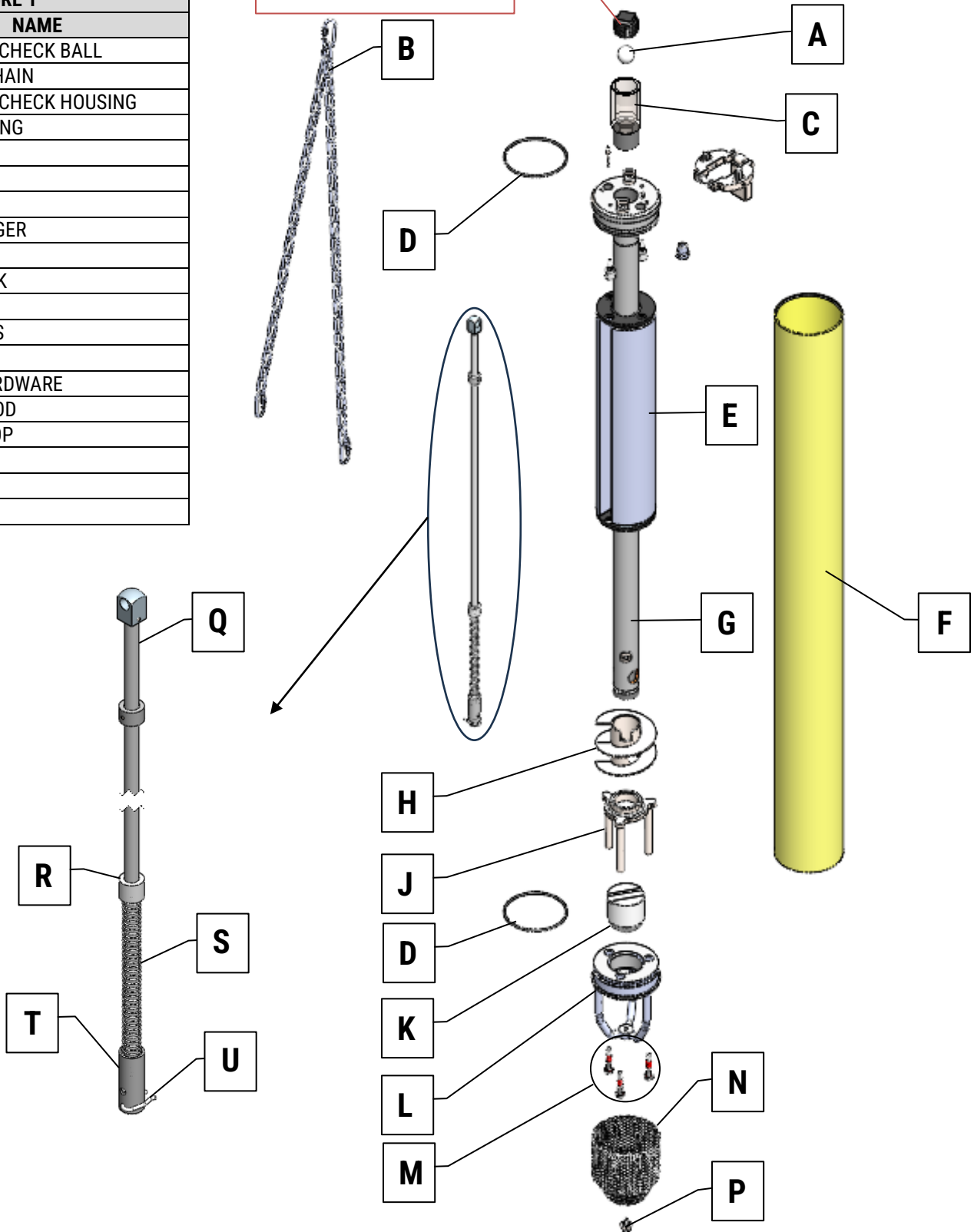

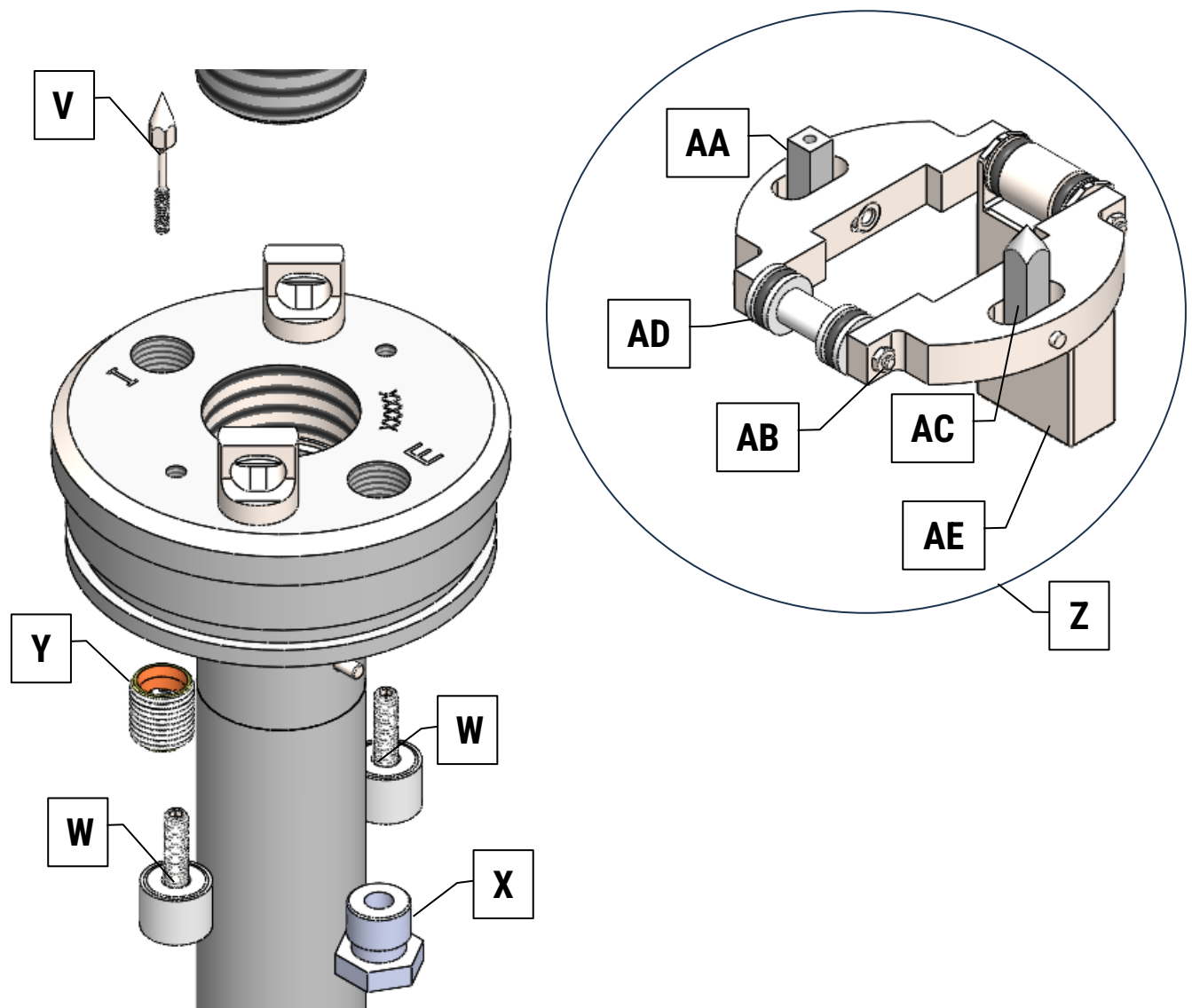
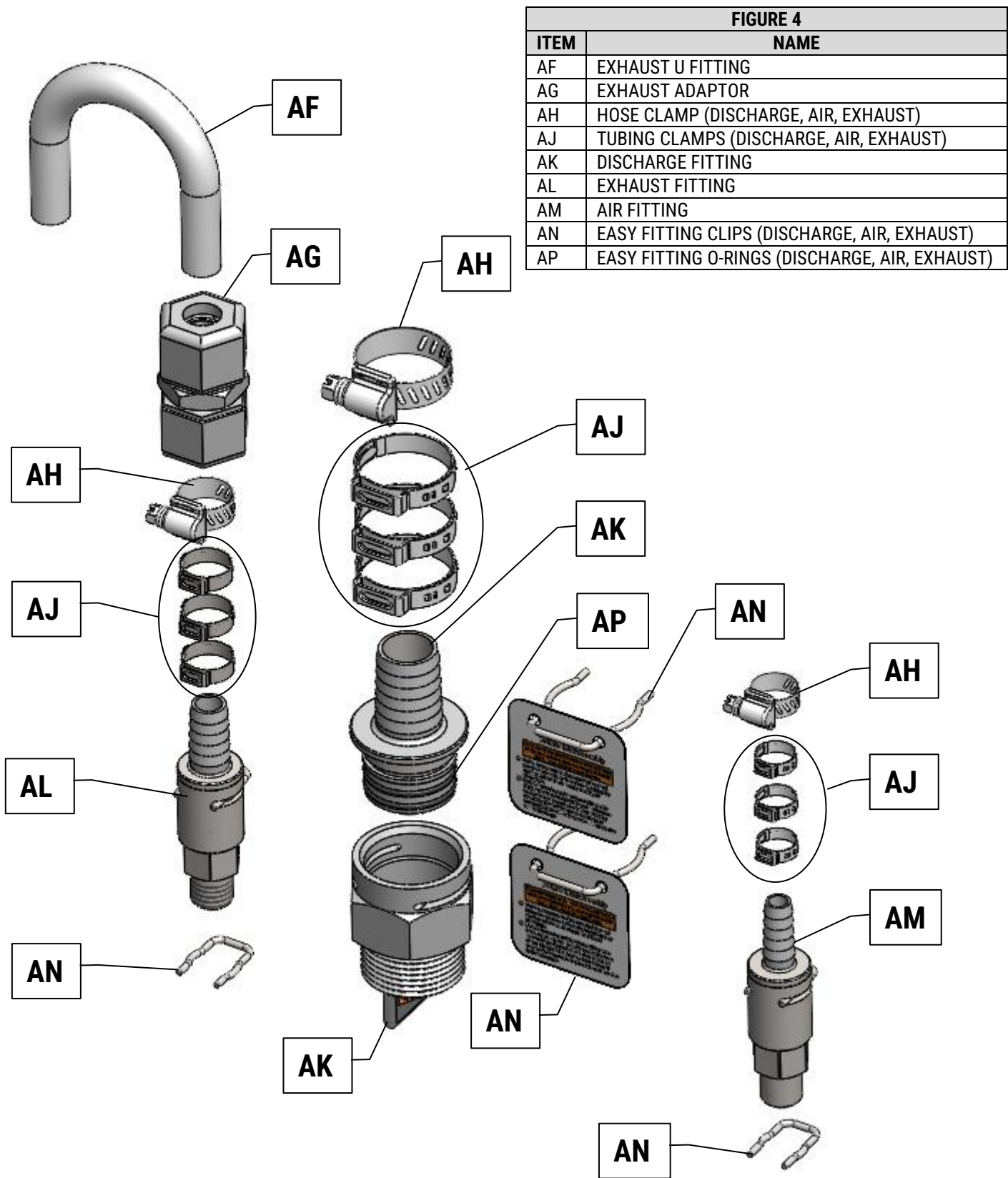

FIGURE 4	
ITEM	NAME
V	AIR POPPET
W	MAGNET
X	EXHAUST SEAT
Y	AIR SEAT
Z	LEVER ASSEMBLY
AA	AIR POPPET CONNECTOR
AB	LEVER NUT (4-40SS)
AC	EXHAUST POPPET
AD	LEVER HALF O-RINGS
AE	COUNTERWEIGHT



PARTS

				PART NUMBER				
				303295	2016745	2016746	2016747	2016748
CLEANING AND REBUILT KITS				KIT, AP4 120 PSI - ADVANCED REBUILD	KIT, AP4.5 120 PSI - ADVANCED REBUILD	KIT, AP4 LOW DRAW DOWN - ADVANCED REBUILD	KIT, AP4 VISCOUS FLUID - ADVANCED REBUILD	KIT, AP4 BASIC CLEANING BOTTOM LOAD 7/8 BALL
ITEM	DESCRIPTION		REFERENCE					
A	DISCHARGE CHECK BALL	7/8 IN	ENV201852	X	X	X	X	X
		1 IN	ENV201744					
D	CASING O-RING	4 IN	ENV206273	2X	2X	2X	2X	2X
		4.5 IN	ENV202901		2X			
K	INLET CHECK	SHORT, LONG, LTD	ENV202829	X	X			
		LDD, VISCOUS	ENV206112			X	X	
M	INLET BOLTS		ENV206362	3X	3X	3X	3X	3X
N	SCREEN		ENV206198					
P	SCREEN HARDWARE (BOLT, LOCK WASHER, WASHER)		MULTIPLE					
Q	CONTROL ROD	LDD	303090					
		SHORT, LTD	42053					
		VISCOUS	ENV206327					
		LONG	303087					
R	SLIDING STOP	LEGACY	303088					
		ALL PUMPS	ENV201210					
S	SPRING	ADDITIONAL VISCOUS	ENV205902					
		LDD	ENV201628					
T	SPRING CUP	SHORT, LONG, LEGACY	ENV200351					
		VISCOUS UPPER	ENV205916					
		VISCOUS LOWER	ENV205871					
		LDD	ENV201664					
U	HAIR PIN	SHORT	42055					
		LTD	42215					
		LONG / LEGACY	ENV201211					
		VISCOUS	ENV201664					
V	INTAKE POPPET	LDD	ENV206247					
V	INTAKE POPPET	SHORT, LTD, LEGACY	ENV201614	X	X			
		LDD, VISCOUS	ENV201615			X	X	
X	EXHAUST SEAT	SHORT, LTD, LONG, VISCOUS, LEGACY	42166	X	X		X	
		LDD	ENV205543			X		
Z	LEVER ASSEMBLY	LDD	303208					
		SHORT, LTD, LONG, LEGACY	303204					
		VISCOUS	303206					
AA	AIR POPPET CONNECTOR	SHORT, LTD, VLEGACY	ENV201616	X	X			
		LDD	ENV201617			X		
		VISCOUS	ENV205899				X	
AB	LEVER NUT (4-40SS)		ENV202889	2X	2X	2X	2X	
AC	EXHAUST POPPET	SHORT, LTD, LEGACY	ENV201623	X	X			
		LDD	ENV205542			X		
		VISCOUS	ENV205898				X	
AD	LEVER HALF O-RINGS		ENV200496	4X	4X	4X	4X	

LARGE QTY. KITS				PART NUMBER			
				2016761	2016762	2016763	2016764
				KIT, AP4 CASING O-RING 2-235 (10 PK)	KIT, AP4 INLET BOLTS (15 PK)	KIT, AP4 LEVER NUT (20 PK)	KIT, AP4 CONTROL ROD HAIRPIN (5 PK)
ITEM	DESCRIPTION	REFERENCE					
A	DISCHARGE CHECK BALL	7/8 IN	ENV201852				
		1 IN	ENV201744				
D	CASING O-RING	4 IN	ENV206273	10X			
		4.5 IN	ENV202901				
M	INLET BOLTS	ENV206362		15X			
P	SCREEN HARDWARE (BOLT, LOCK WASHER, WASHER)	MULTIPLE					
S	SPRING	LDD	ENV201628				
		SHORT, LONG, LEGACY	ENV200351				
		VISCOUS UPPER	ENV205916				
		VISCOUS LOWER	ENV205871				
U	HAIR PIN	ENV206247				5X	
W	MAGNET	ENV301083					
AB	LEVER NUT	ENV202889			20X		
AD	LEVER HALF O-RINGS	ENV200496					
NR	LEVER PIN (NOT REFERENCED)	ENV203987					

PART NUMBER										
2016765	2016782	2016783	2016785	2016784	2016766	2016767	2016755	2016786	2061818	2016769
KIT, AP4 DISCHARGE CHECK BALL 7/8 IN (5PK)	KIT, AP4 DISCHARGE CHECK BALL 1 IN (5PK)	KIT, AP4 BASIC CLEANING BOTTOM LOAD 7/8 BALL (5PK)	KIT, AP4 BASIC CLEANING TOP LOAD 1 IN BALL (5PK)	KIT, AP4.5 BASIC CLEANING (5PK)	KIT, AP4 STANDARD SPRING (5 PK)	KIT, AP4 LOW DRAW DOWN SPRING (5 PK)	KIT, AP4 SCREEN HARDWARE (5PK)	KIT, AP4 MAGNET REPLACEMENT (2PK)	KIT, AP4 LEVER HALF O- RINGS 2-109 (20 PK)	KIT, AP4 LEGACY LEVER PIN (5 PK)
5X		5X		5X						
	5X		5X							
		10X	10X	10X						
				10X						
		15X	15X	15X						
							5X			
					5X	5X				
								2X		
									20X	
										5X

				PART NUMBER	
				302066	
FITTINGS KITS					
KIT,AP4 NO FTG SS					
ITEM	DESCRIPTION			REFERENCE	
AF	EXHAUST U FITTING			ENV205887	
AG	EXHAUST CONNECTOR			ENV206778	
AH	HOSE CLAMP (DISCHARGE, AIR, EXHAUST)	DISCHARGE	1 IN	ENV202804	
			3/4 IN	ENV203313	
		EXHAUST	1/2 IN	ENV204897	
			AIR	3/8 IN	ENV204896
AJ	TUBING CLAMPS (DISCHARGE, AIR, EXHAUST)	DISCHARGE	1 1/4 IN	ENV205864	
			1 IN	ENV205863	
		EXHAUST	5/8 IN	ENV205621	
			AIR	1/2 IN	ENV202186
AK	DISCHARGE FITTING	EASY FITTING - MALE	1 1/4 IN	ENV206218	
			1 IN	ENV206217	
		EASY FITTING - FEMALE		ENV206216	
		MALE BARB		ENV205582	
MALE - FEMALE ADAPTOR		ENV205598		X	
AL	EXHAUST FITTING	EASY FITTING - ASSEMBLED		303033	
		EASY FITTING - MALE		ENV206214	
		EASY FITTING - FEMALE		ENV206213	
		MALE BARB		ENV205591	
AM	AIR FITTING	EASY FITTING - ASSEMBLED		303032	
		EASY FITTING - MALE		ENV206211	
		EASY FITTING - FEMALE		ENV206210	
		MALE BARB		ENV205594	
AN	EASY FITTING CLIPS (DISCHARGE, AIR, EXHAUST)	DISCHARGE		303011	
		EXHAUST		ENV206215	
		AIR		ENV206212	
AP	EASY FITTING O-RINGS (DISCHARGE, AIR, EXHAUST)	DISCHARGE		ENV206222	
		EXHAUST		ENV206223	
		AIR		ENV206224	
NR	WIRE ROPE SADDLE KIT (NOT REFERANCED)			990175	

PART NUMBER								
303012	303013	303016	303017	303032	303033	990175	2016768	ENV301193
KIT,EASY-FITTINGS MALE ONLY 1 IN TUBE OR 3/4 HOSE	KIT,EASY-FITTINGS MALE ONLY 1-1/4 IN TUBE OR 1 IN HOSE	KIT,EASY-FITTINGS 1 IN TUBE OR 3/4 IN HOSE	KIT,EASY-FITTINGS 1-1/4 IN TUBE OR 1 IN HOSE	KIT,EASY-FITTING AIR SUBASSEMBLY	KIT,EASY-FITTING EXHAUST SUBASSEMBLY	KIT,WIRE ROPE ASSEMBLY 2 END 5/32 SADDLE	KIT, EASY FITTING REPLACEMENT O-RINGS AND CLIPS (5 PK)	KIT,AP4 FITTINGS 1 HOSE SS
X	X	X	X					X
X	X	X	X					X
	X		X					X
X		X						
X	X	X	X					X
X	X	X	X					X
	3X		3X					
3X		3X						
3X	3X	3X	3X					
3X	3X	3X	3X					
	X		X					
X		X						
		X	X					
								X
		X	X					
X	X				X			
					X			
								X
		X	X					
X	X			X				
				X				
								X
2X	2X	2X	2X				5X	
2X	2X	2X	2X		2X		5X	
2X	2X	2X	2X	2X			5X	
2X	2X	2X	2X				10X	
2X	2X	2X	2X		2X		10X	
2X	2X	2X	2X	2X			10X	
						X		

INDIVIDUAL

ITEM	DESCRIPTION		REFERENCE
B	SUPPORT CHAIN		300984
C	DISCRHAGE CHECK HOUSING	TOP LOAD	303057
		BOTTOM LOAD	ENV205601
E	FLOAT	LDD	302598
		VISCOUS FLUID	302509
		VISCOUS FLUID FLOAT GUIDE	ENV302480
		ULTRA	303209
		HI TEMP	303210
		4.5 ULTRA	303270
		4.5 HIGH TEMP	303311
F	CASING	LDD	ENV206285
		VISCOUS FLUID	ENV206284
		SHORT ULRTA	ENV206591
		SHORT ULTRA HI TEMP	ENV206588
		SHORT ULRTA XTREME	42034
		SHORT ULTRA HI TEMP XTREME	42035
		LTD	42222
		LONG ULTRA	ENV206592
		LONG ULTRA HI TEMP	ENV206589
		4.5 ULTRA	ENV206570
		4.5 ULTRA HI TEMP	ENV206781
G	FRAME	LDD	ENV42157
		LTD	ENV42486EP
		SHORT ULTRA, VISCOUS FLUID, HI TEMP	ENV42145EP
		SHORT ULTRA XTREME, HI TEMP XTREME	ENV42144EP
		LONG	ENV42156EP
H	XTREME AUGER	4 IN	41806
		4.5 IN	42133
J	SPIDER		ENV206195
K	INLET CHECK	LDD, VISCOUS FLUID	ENV206112
		SHORT, LONG, LTD, LEGACY	ENV202829
L	INLET	TOP LOAD	ENV206426
		BOTTOM LOAD	ENV206187
Y	AIR SEAT	120 PSI	ENV301084
		200 PSI	ENV301085
AD	COUNTERWEIGHT	LDD	ENV201520
		SHORT, LONG, LTD, LEGACY	ENV206009
NR	4.5 ADAPTOR (NOT REFERANCED)		42131
	LTD PUMP INSTALL KIT (NOT REFERANCED)		42321

EASY FITTING INSTALL

Note: Easy Fittings are not included with AP4 pumps. A separate kit will need to be purchased. See Fittings Kits available on page 36 & 37.

REQUIRED TOOLS

- Imperial Open End Wrenches
- Large Adjustable Wrench
- Screwdriver

1. Remove Shipping Cover (A)
2. Install Discharge Easy Fitting into Discharge Check, finger tight. (AK)
3. Take note of "I" and "E" on top of head.
4. Install Air Easy Fitting into "I" port on head, finger tight. This has the smaller of the 2 ports.(AM)
5. Install Exhaust Easy Fitting into "E" port on head, finger tight. This has the larger of the 2 ports.(AL)
6. Tighten Discharge Easy Fitting to 1.5-2.5 turns from finger tight.
7. Tighten Air and Exhaust Easy Fittings to 2-3 turns from finger tight.

See workshop video at www.qedenv.com

CLEANING

Note:

- The AP4 and AP4.5 Ultra and High Temp. use non-stick finishes on the float and discharge tube. To protect these finishes, never use any type of abrasive pad, wire brush, steel wool, or sandpaper to clean these two components.
- The AP4 and AP4.5 Ultra and High Temp. use non-stick finishes on the float and discharge tube. To protect these finishes never use any high acidic cleaning agent (i.e., vinegar)
- To aid in cleaning a pressure washer may be used at a max pressure of 40 psi (2.76 bar)

Caution:

- Wear chemically resistant rubber gloves, boots, and coveralls when handling the AutoPump and fluid discharge hose to avoid skin contact with the fluid being removed.
- Wear safety goggles when working with the AutoPump System to protect eyes from any splashing or pressure release.

REQUIRED TOOLS

- Set of socket wrenches
- Set of Imperial open end wrenches
- Set of adjustable wrenches
- Pipe wrench
- Rubber mallet
- Torque wrench
- PTFE Tape
- PTFE grease



DISASSEMBLY

8. Disconnect Air Supply, Exhaust, and Fluid Discharge lines from pump. (AM,AL, AK)
9. Remove discharge fitting, retain fitting, remove and replace any residual PTFE tape. (AK)
10. Remove discharge check ball, Discard. (A)
11. Remove Screen hardware and Screen. (N, P)
12. Remove 3 inlet bolts and inlet. (M, L)
13. Remove inlet check. (K)
14. Remove Casing. (F)
15. Remove Spider, remove and replace any residual PTFE tape on Frame. (J, G)
16. Remove 2 casing O-rings and discard. (D)
17. Follow next steps for cleaning the pump.

CLEANING THE PUMP

1. Gently brush off built-up solids from the float, frame, pump casing, and control rod. (E, G, F, Q)
2. Visually inspect the frame for scale build-up or debris. Also, do the same with the float that slides up and down on the frame.
3. Should there be scale deposits on either the frame or float, remove the float from the frame as follows: Remove the small steel hairpin from the bottom spring cup. Removing the spring cup will allow you to remove the spring, sliding stop, and float from the frame. (S, R, E)
4. Parts can now be cleaned using a damp cloth. Use the appropriate cleaning procedure for your product.
Use only for AGGRESSIVE FLUIDS: To aid in cleaning, the frame can be soaked in vinegar. To remove tougher build-up, scour pads that are made for non-stick cookware can be used.
Use only for ULTRA and High Temp: To aid in cleaning, use a gentle soap solution (i.e., Dish Soap) through the pump to remove free product particles.
Use only for LTD pump: check exhaust port for buildup or scaling. Remove all with compressed air or wire brush.
5. The white plastic control rod is the next component to be cleaned. The control rod is the item that fits through the smaller hole in the float plate and is adjacent to the frame in the assembled pump. To clean

the control rod, use an abrasive pad or a razor or utility knife (not sandpaper).

6. The final component to be cleaned is the outer casing. The fastest and most effective way to clean out the inside surface of the pump casing is to use a three-stone honing tool. The technique is to move the hone in and out a half dozen times or so, through each end of the casing. The time for the casing cleaning should take no longer than 5 minutes with this method.

REASSEMBLY

1. Install spider, fully seat into bottom of Frame. (J, G)
2. Reinstall new casing O-rings and a thin layer of lubricant. (D)
3. Reinstall casing. (F)
4. Reinstall inlet check. (K)
5. Reinstall inlet and 3 inlet bolts. Torque to 75 in-lbs. (L, M)
6. Reinstall screen and hardware. Torque to 75 in-lbs. (N, P)
7. Install discharge check ball. (A)
8. Install discharge check fitting. Install finger tight, then using wrench 1.5 – 2.5 turns past finger tight. (AK)

TROUBLESHOOTING

POSSIBLE CAUSES	SYMPTOMS		
	PUMP NOT CYCLING	PUMP CYCLES, WITH REDUCED OR NO DISCHARGE	AIR IN FLUID DISCHARGE
1. Air Supply	X		X
2. Fluid Level	X		
3. Air Exhaust Restricted	X		X
4. Fluid Inlet Clogged	X		
5. Debris, Scaled or Very Viscous fluid	X	X	X
6. Float pins	X		X
7. Lever pivot wear	X		X
8. Debris in Air Inlet Valve	X		
9. Fluid Check Valve		X	
10. Valve Timing	X		

1. Air Supply:

- If the air pressure is too low, or if the flow is severely restricted, the pump will not cycle. Check the flow by inserting the pump air fitting part way into the air line socket. A healthy discharge of air should result.
- If the air pressure exceeds the design limitations of the pump, the pump may fail to cycle, or the exhaust valve may have locked up and cause air to enter the fluid discharge.

2. Fluid Level:

- The fluid level must be above the fluid inlet on a Top-Loading pump. On a Bottom-Loading pump, the fluid must be no lower than 9 inches below the head of the pump.

3. Air Exhaust Restricted:

- The exhaust line must not be kinked, plugged, or too small in diameter.
- The air exhaust outlet must be above the fluid level.
- If the air exhaust to atmosphere (outside the well) and a vacuum is drawn on the well, the pump may fail to fill. In order for the pump to fill under these adverse conditions, the pump must be submerged to make up for the pressure difference between the atmosphere and the partial vacuum in the well.
- The pressure difference, expressed as feet of water column (FT. W.C.), is how far the fluid must be above the pump before it can fill.
- Ice may be forming on the exhaust valve seat due to the temperature drop that accompanies expansion of compressed air. Restrict the exhaust to lower the expansion rate of exhaust. Restrict the air inlet hose or lower the pressure to reduce the rate of incoming compressed air. The previous three suggestions may reduce the flow rate from the pump. Submerge the head of the pump, if it is not already submerged. Protect the air lines from low temperatures and freezing by burial or insulation.

4. Fluid Inlet Clogged:

- If the fluid inlet screen is clogged with debris, or if a Bottom-Loading pump is on the bottom of the well, water cannot enter the pump.

5. Debris, Scale, or very Viscous Fluid:

- If debris, scale or a very viscous fluid has accumulated inside the pump, the float may not move freely up and down, or the control rod may not slide easily through the float.
- Clean the float, control rod, and casing. See Chapter 6 for cleaning instructions.

6. Lever Pivot Wear:

- Grasp the center of the lever with thumb and forefinger. Rotate the lever to horizontal.
- Push up and down, toward and away from the head. Confirm that there is less than 1/32 inch of movement.
- Replace the levers if the pivot hole is worn

7. Debris in Air Inlet Valve: (First check #6-Lever Pivot Wear)

- Open the pump. Connect the air supply. Pull the control rod down. Listen to determine if air leaks through. If so, clean the valve by blowing air or water through it from both ends.
- If air still leaks through the valve with the control rod down, the air-hose must be removed to access the valve inlet to check for debris in the valve or in the hose pigtail.
- Push the rod upwards. If little or no air passes through, remove the air-in hose to access the valve inlet. Blow air through the valve from the poppet side to clear debris from the ball and seat

8. Fluid Check Valves:

- Open the pump. Hold the pump vertically and pour water into the discharge check valve. If water flows through, clean the valve.
- Remove the valve and use emery cloth or a very fine sand paper to polish the surface where the ball seats.
- If the pump is a Bottom-Loading design, inspect the seat of the bottom check valve for debris and wear. Clean or replace if necessary.
- If the pump is a Top-Loading design, remove the fluid inlet check valve and inspect the seating surface and the ball for debris and wear.

9. Air Inlet Valve Timing:

- First check lever pivot wear per #6
- Call the QED Service Department for correct air valve timing for your pump

PATENT INFORMATION

The equipment in this manual is protected under U.S. and foreign patents issued and pending. For a complete list of patents visit www.graco.com/patents.

The equipment in this manual is protected under Registered Trademarks. For a complete list of Registered Trademarks and Trademarks, visit www.graco.com/trademarks.

TERMS, CONDITIONS & WARRANTY

QED Environmental warrants all equipment, which is manufactured by QED Environmental and bearing its name to be free from defects in material and workmanship on the date of sale to the original purchaser for use. With the exception of any special, extended, or limited warranty published by QED Environmental, QED Environmental will, for a period of twelve months from the date of sale, repair or replace any part of the equipment determined by QED Environmental to be defective. This warranty applies only when the equipment is installed, operated and maintained in accordance with QED Environmental's written recommendations.

This warranty does not cover, and QED Environmental shall not be liable for general wear and tear, or any malfunction, damage or wear caused by faulty installation, misapplication, abrasion, corrosion, inadequate or improper maintenance, negligence, accident, tampering, or substitution of non-QED Environmental component parts. Nor shall QED Environmental be liable for malfunction, damage or wear caused by the incompatibility of QED Environmental equipment with structures, accessories, equipment or materials not supplied by QED Environmental, or the improper design, manufacture, installation, operation or maintenance of structures, accessories, equipment or materials not supplied by QED Environmental.

This warranty is conditioned upon the prepaid return of the equipment claimed to be defective to an authorized QED Environmental distributor for verification of the claimed defect. If the claimed defect is verified, QED Environmental will repair or replace free of charge any defective parts. The equipment will be returned to the original purchaser transportation prepaid. If inspection of the equipment does not disclose any defect in material or workmanship, repairs will be made at a reasonable charge, which charges may include the costs of parts, labor, and transportation.

THIS WARRANTY IS EXCLUSIVE, AND IS IN LIEU OF ANY OTHER WARRANTIES, EXPRESS OR IMPLIED, INCLUDING BUT NOT LIMITED TO WARRANTY OF MERCHANTABILITY OR WARRANTY OF FITNESS FOR A PARTICULAR PURPOSE.

QED Environmental's sole obligation and buyer's sole remedy for any breach of warranty shall be as set forth above. The buyer agrees that no other remedy (including, but not limited to, incidental or consequential damages for lost profits, lost sales, injury to person or property, or any other incidental or consequential loss) shall be available. Any action for breach of warranty must be brought within two (2) years of the date of sale.

QED ENVIRONMENTAL MAKES NO WARRANTY, AND DISCLAIMS ALL IMPLIED WARRANTIES OF MERCHANTABILITY AND FITNESS FOR A PARTICULAR PURPOSE, IN CONNECTION WITH ACCESSORIES, EQUIPMENT, MATERIALS OR COMPONENTS SOLD BUT NOT MANUFACTURED BY QED ENVIRONMENTAL. These items sold, but not manufactured by QED Environmental (such as electric motors, switches, hose, etc.), are subject to the warranty, if any, of their manufacturer. QED Environmental will provide purchaser with reasonable assistance in making any claim for breach of these warranties.

In no event will QED Environmental be liable for indirect, incidental, special or consequential damages resulting from QED Environmental supplying equipment hereunder, or the furnishing, performance, or use of any products or other goods sold hereto, whether due to a breach of contract, breach of warranty, the negligence of QED Environmental, or otherwise.

Some products do carry special, extended, or limited warranties outside of the QED Environmental Standard Warranty. The warranty for each product is found on the back of the instruction form or parts list included with the product or in the product manual.

QED INFORMATION

For the latest information about QED products, visit www.qedenv.com

TO PLACE AN ORDER, contact QED Environmental or your local representative.

Phone: 734-995-2547 or **Toll Free:** 1-800-624-2026 **Email:** info@qedenv.com

A Graco Company
QED Environmental Systems Inc.
Headquarters: Dexter, MI

QED Environmental Systems Inc. 2355 Bishop Circle West Dexter, MI 48103
www.qedenv.com